

# CITY OF MESQUITE TEXAS

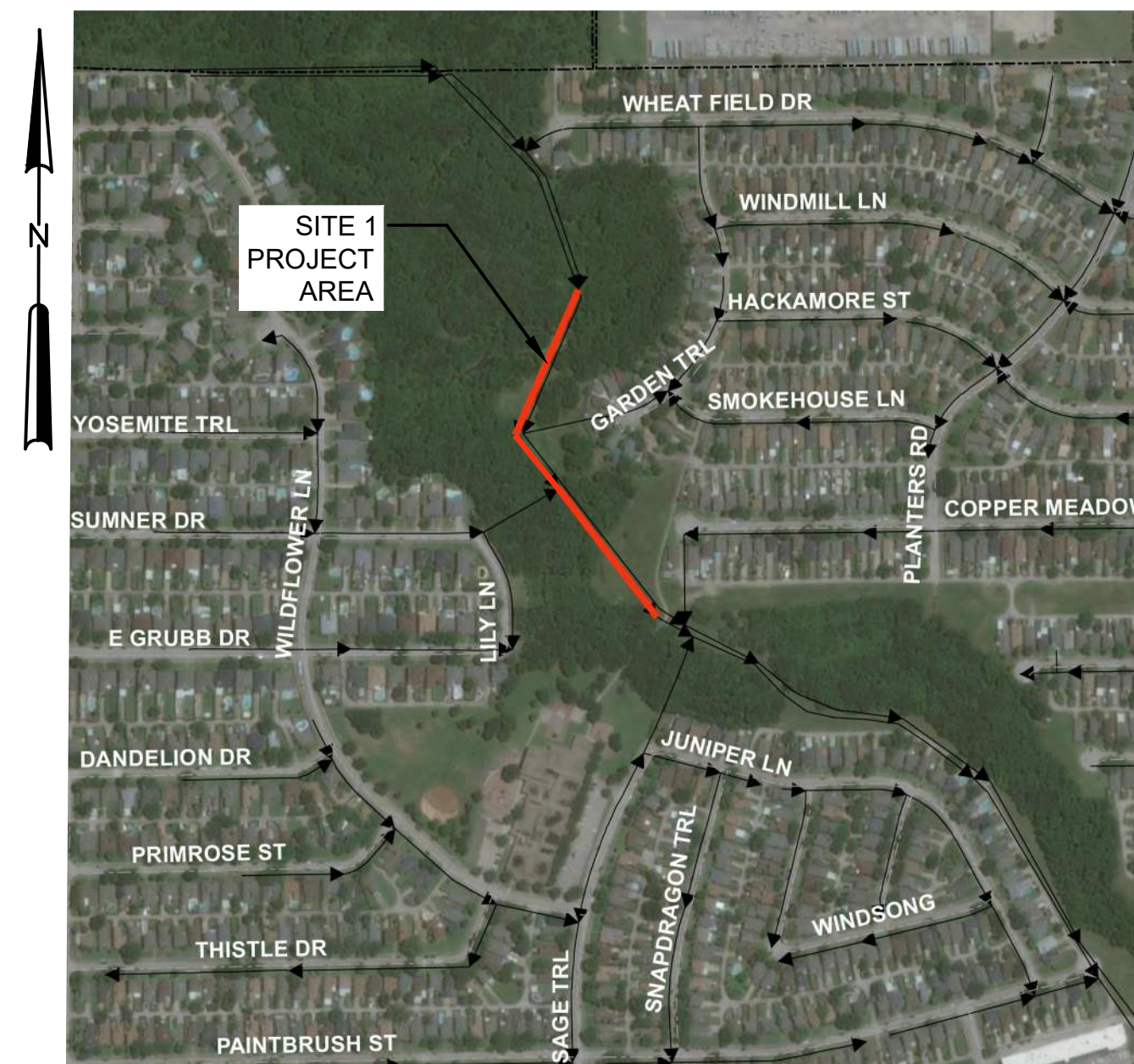

# SAMUELL PARKS FARMS/SCYENE SEWER MAIN REPAIR/REHABILITATION

CITY PROJECT NO. 2025-073  
MAY 2025



SITE 1  
LOCATION MAP  
SCALE: 1" = 500'

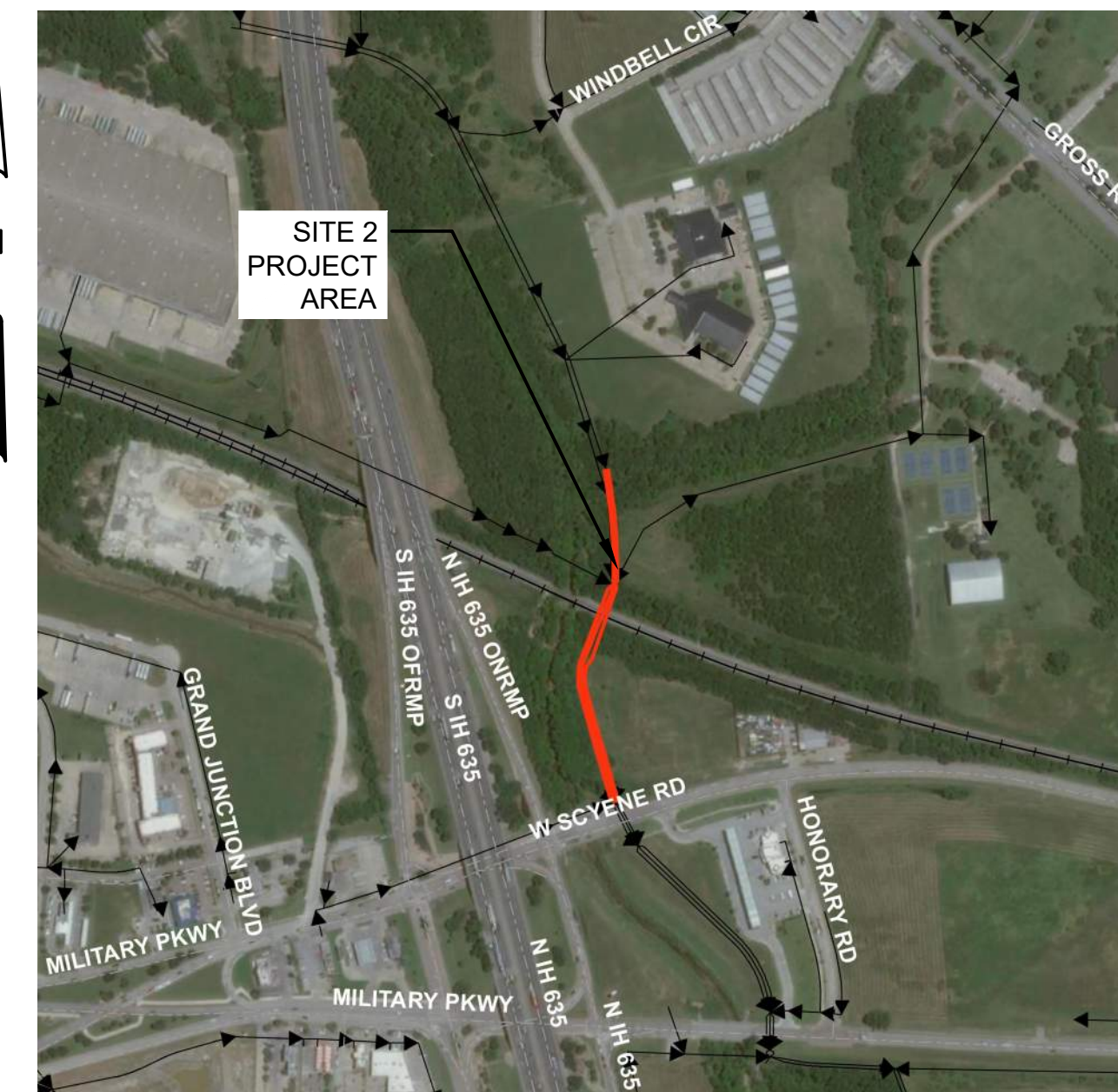

SITE 2  
LOCATION MAP  
SCALE: 1" = 500'

INDEX OF DRAWINGS	
<b>GENERAL</b>	
G001	COVER SHEET
G002	QUANTITY TABLE, LEGEND AND ABBREVIATIONS
<b>CIVIL</b>	
C001	OVERALL MAP AND SURVEY DATUM SITE 1 AND 2
C002	SITE 1 - SEWER REHABILITATION PLAN
C003	SITE 1 - EROSION CONTROL AND ACCESS PLAN
C004	SITE 2 - SEWER REHABILITATION PLAN AND PROFILE
C005	SITE 2 - EROSION CONTROL AND ACCESS PLAN
C006	CITY OF MESQUITE WASTEWATER DESIGN REQUIREMENTS
C007	CITY OF MESQUITE PUBLIC WORKS DEPARTMENT MISCELLANEOUS DETAILS
C008	CITY OF MESQUITE PUBLIC WORKS DEPARTMENT WASTEWATER DETAILS
CITY OF MESQUITE GENERAL NOTES	
CITY OF MESQUITE WASTEWATER NOTES	
<b>STRUCTURAL</b>	
S001	STRUCTURAL GENERAL NOTES
S002	STRUCTURAL JUNCTION BOX SM 6186 DEMOLITION PLAN AND SECTION
S003	STRUCTURAL JUNCTION BOX SM 6186 PLANS
S004	STRUCTURAL JUNCTION BOX SM 6186 SECTIONS
S005	STRUCTURAL PROPOSED JUNCTION BOX PLANS
S006	STRUCTURAL PROPOSED JUNCTION BOX SECTIONS
S007	STRUCTURAL JUNCTION BOX SM 6183 PLANS
S008	STRUCTURAL JUNCTION BOX SM 6183 SECTIONS
SD1	STRUCTURAL STANDARD DETAILS SHEET 1
SD2	STRUCTURAL STANDARD DETAILS SHEET 2
<b>RECORD DRAWINGS</b>	
AS-BUILT - EXISTING JUNCTION BOXES AT SM 6183 & 6186 PLANS AND SECTIONS	
EXISTING CONCRETE CULVERT PLAN AND SECTION	



## Hazen

HAZEN AND SAWYER  
8150 NORTH CENTRAL EXPRESSWAY  
TOWER II SUITE 700  
DALLAS, TEXAS 75206  
TBPELS Reg. No. F-13618























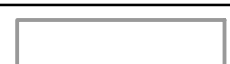
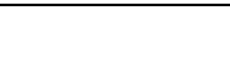

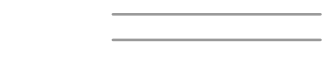

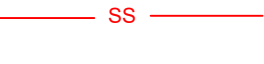

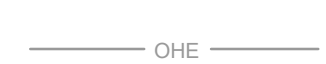
**QUANTITY TABLE**

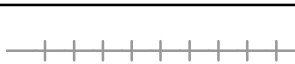
BID ITEM NO.	BID ITEM DESCRIPTION	TOTAL BID QUANTITIES	UNIT
1	Mobilization (5 %)	1	LS
2	Heavy Cleaning*	8	HR
3	Mobile Odor Control Units*	6	MO
4	Internal Joint Seal (48")*	1	EA
5	Internal Joint Seal (36")*	2	EA
6	Internal Joint Seal (27")*	3	EA
7	Pre-Lining (48")*	200	LF
8	Pre-Lining (36")*	420	LF
9	Pre-Lining (27")*	500	LF
10	Polymeric Rehab Existing Manhole*	31	VF
11	48" Diameter Polymer Concrete Manhole (10'-12' depth)*	1	EA
12	60" Diameter Polymer Concrete Manhole (10'-12' depth)*	1	EA
13	Cured-in-Place-Pipe Liner (48")	350	LF
14	Cured-in-Place-Pipe Liner (36")	2,100	LF
15	Cured-in-Place-Pipe Liner (27")	1,210	LF
16	60" Diameter Polymer Concrete Manhole (up to 10' depth)	1	EA
17	60" Diameter Polymer Concrete Manhole (18'-20' depth)	1	EA
18	60" Diameter Polymer Concrete Manhole (12'-14' depth)	1	EA
19	Point Repair 48" DI AWWA 151 Class 54 Aerial Crosssing (up to 40' length)	1	EA
20	Point Repair 27" PVC SDR 26 (up to 10' length) Installed by Open Cut	1	EA
21	Hydromulch	9,200	SY
22	SWPPP and Installation	1	LS
23	Sewer Bypass Pumping Site 1	1	LS
24	Sewer Bypass Pumping Site 2	1	LS
25	Proposed Junction Box at SM Site 2	1	LS
26	Remove and Replace Existing Junction Box at SM 6186	1	LS
27	Remove and Replace Existing Junction Box at SM 6183	1	LS
28	Abandon Existing Sanitary Sewer Manhole Site 2	1	EA
29	Plug Existing 6" Sanitary Sewer Site 2	1	EA
30	Abandon and Grout Fill Existing 6" Sanitary Sewer Site 2	1	CY
31	Trench Safety	150	LF
32	Allowance for Additional Construction Related Cost	1	ALLOWANCE

**NOTE:**

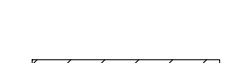
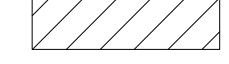
REFER TO SPECIFICATIONS SECTION 01 11 00-1 "SUMMARY OF WORK" FOR A DETAILED SCOPE OF WORK.

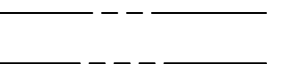
ITEMS LISTED WITH ONE ASTERISK (\*) REQUIRE ENGINEER/OWNER APPROVAL PRIOR TO INSTALLATION OR USE.

PROJECT DATA	SYMBOLS	LEGEND	ABBREVIATIONS
<p>1 PROJECT NAME:</p> <p>2 PROJECT LOCATION/ADDRESS: MESQUITE, TEXAS</p> <p>3 PRESENT AND PROPOSED USE: SANITARY SEWER</p> <p>4 OWNER: CITY OF MESQUITE 1515 N GALLOWAY AVE MESQUITE, TX 75149</p> <p>5 ENGINEER: HAZEN AND SAWYER 8150 N. CENTRAL EXPRESSWAY, SUITE 700 DALLAS, TEXAS 75206 (214) 382-5750</p> <p>6 SURVEYOR: 1519 LLC 1200 WEST MAGNOLIA AVENUE, SUITE 300 FORT WORTH, TEXAS 76104 214-484-8586</p>	<p>EXISTING      NEW / REHAB</p> <p>SANITARY MANHOLE  </p> <p>FIRE HYDRANT </p> <p>LIGHT POLE </p> <p>POWER POLE </p> <p>STORM MANHOLE </p> <p>WATER VALVE </p> <p>ROAD SIGNAGE </p> <p>CONTROL POINT </p> <p>BENCHMARK </p> <p>TREE </p>	<p>EXISTING      NEW / REHAB</p> <p>BUILDING/STRUCTURE </p> <p>CONSTRUCTION ENTRANCE </p> <p>CONCRETE CURB AND GUTTER </p> <p>CONCRETE SIDEWALK </p> <p>SAN. SEWER (GRAVITY)  </p> <p>PROPOSED POINT REPAIR </p> <p>STORM SEWER </p> <p>OVERHEAD ELEC. </p> <p>WATER MAIN </p> <p>GAS LINE </p> <p>RAILROAD TRACKS </p> <p>APPROXIMATE WOODLINE </p> <p>100 YR. FLOODPLAIN </p> <p>FLOODPLAIN ELEVATION BOUNDARY </p> <p>CREEK CENTERLINE </p> <p>DEMOLITION </p> <p>SILT FENCE </p> <p>CONTOUR (MAJOR) </p> <p>CONTOUR (MINOR) </p> <p>PROPERTY LINE </p> <p>EASEMENT </p> <p>RIGHT-OF-WAY </p>	<p>CIPP - CURED-IN-PLACE PIPE</p> <p>EOP - EDGE OF PAVEMENT</p> <p>G - GASLINE</p> <p>LP - LIGHT POLE</p> <p>OHE - OVERHEAD ELECTRIC</p> <p>RL - PROPERTY LINE</p> <p>SM - SANITARY MANHOLE</p> <p>SS - SANITARY SEWER</p> <p>W - WATER MAIN</p>

File: C:\USERS\PLASFORDD\ACDC\HAZEN AND SAWYER\6006-000\_ HIGH RISK SEWER MAIN REPAIR\PROJECT FILES\GENERAL\6006-000\_G02\_Saved by PGLASFORD Save date: 5/12/2025 1:23 PM PLOT DATE: 5/12/2025 2:58 PM BY: PGLASFORD

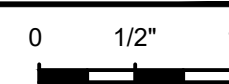
PROJECT ENGINEER:	N. SHAH
DESIGNED BY:	A. REEVES
DRAWN BY:	P. GLASFORD
CHECKED BY:	S. O'ROURKE
IF THIS BAR DOES NOT MEASURE 1" THEN DRAWING IS NOT TO FULL SCALE	
REV	ISSUED FOR      DATE      BY



**Hazen**  
HAZEN AND SAWYER  
8150 NORTH CENTRAL EXPRESSWAY  
TOWER II SUITE 700  
DALLAS, TEXAS 75206  
TBPELS Reg. No. F-13618

05/12/2025



**MESQUITE**  
CITY OF MESQUITE  
TEXAS

**SAMUELL PARKS FARMS/SCYENE  
SEWER MAIN REPAIR/REHABILITATION**

**QUANTITY TABLE, LEGEND AND  
ABBREVIATIONS**

DATE:	MAY 2025
HAZEN NO.:	60006-000
CONTRACT NO.:	2025-073
DRAWING NUMBER:	G002

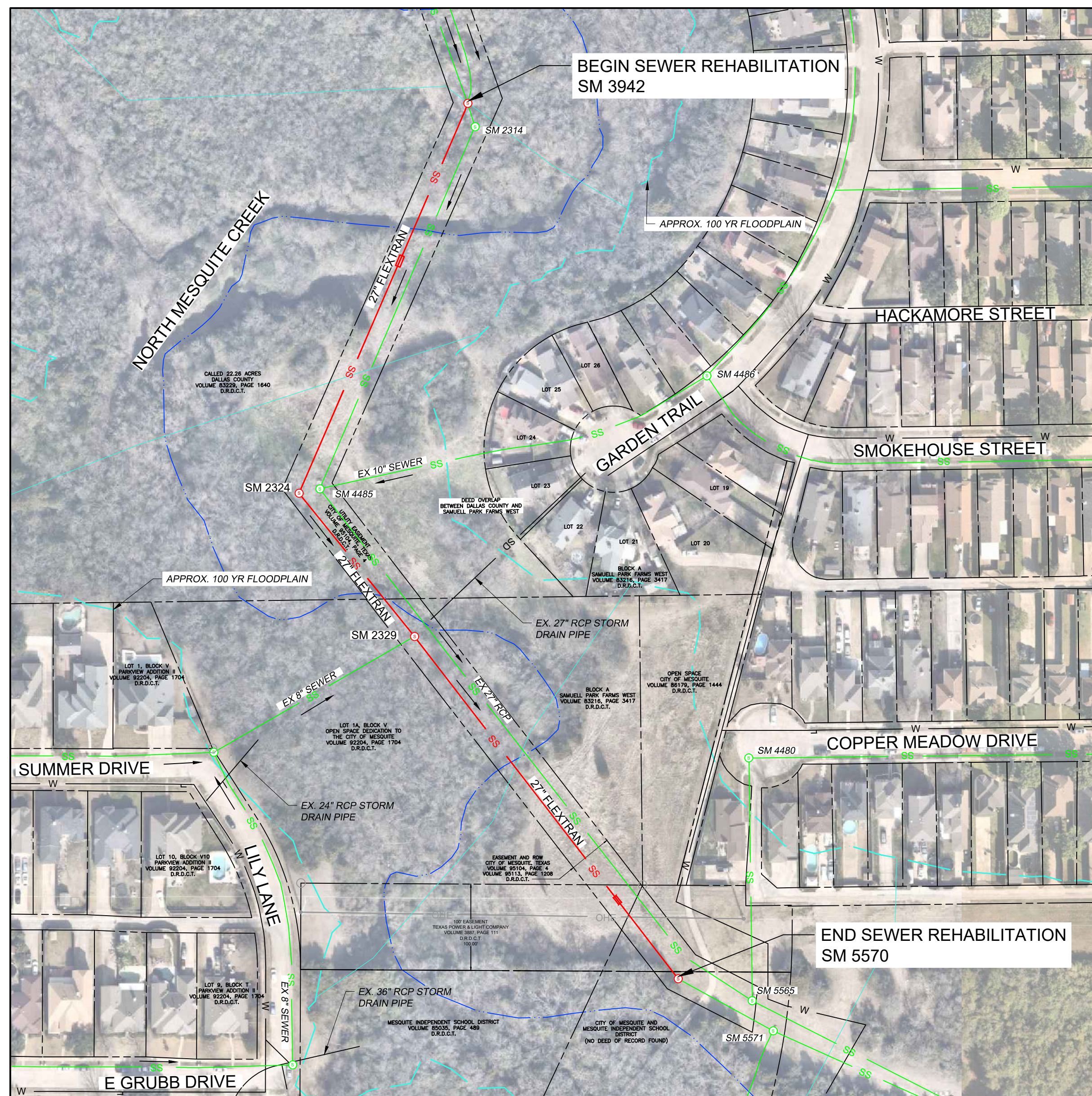

SITE 1 - SEE SHEET C002 - C003

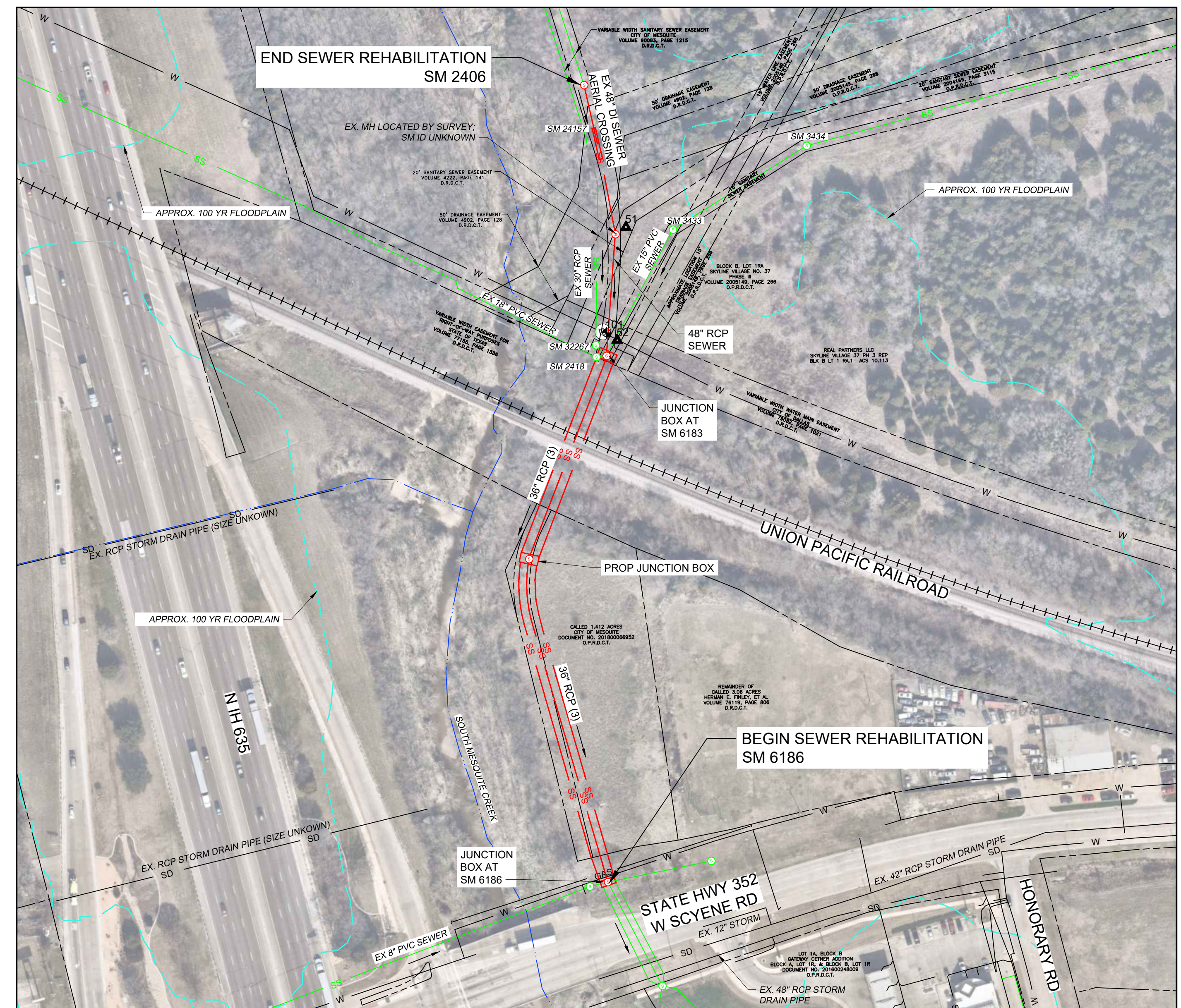

SITE 2 - SEE SHEET C004 - C005

**LEGEND**

- EXISTING SANITARY SEWER (GRAVITY) — SS —
- PROPOSED SEWER REHABILITATION (CIPP) — SS —
- 100 YR. FLOODPLAIN —
- FLOODPLAIN ELEVATION BOUNDARY —
- CREEK CENTERLINE —
- PROPOSED POINT REPAIR □
- REMOVE INTERNAL PIPE LAYER □

**HORIZONTAL DATUM AND BASIS OF BEARINGS**

SURVEY PERFORMED BY 1519 LLC. THE HORIZONTAL DATUM FOR THIS PROJECT IS TEXAS NORTH CENTRAL STATE PLANE COORDINATE SYSTEM, NORTH AMERICAN DATUM OF 1983 (NAD83), NORTH CENTRAL ZONE (4202) AND SCALED TO SURFACE USING THE GRID TO SURFACE FACTOR OF 1.000136506 (0.0 BASE POINT).

**VERTICAL DATUM AND BENCHMARK**

ELEVATIONS ARE BASED ON THE NORTH AMERICAN VERTICAL DATUM OF 1988 (NAVD88) USING GEOID 12B.

POINT NO.	NORTHING	EASTING	ELEVATION	DESCRIPTION
*50	6,970,199.80	2,546,190.84	457.50	1/2" CIRS "1519 CONTROL"
51	6,969,840.18	2,546,294.12	448.70	1/2" CIRS "1519 CONTROL"
52	6,969,697.99	2,546,283.09	447.46	1/2" CIRS "1519 CONTROL"
101	6,969,707.18	2,546,269.74	448.64	BM #1 BOX CUT WITH "X"
*102	6,970,440.83	2,546,265.61	464.16	BM #2 BOX CUT WITH "X"

\*OUTSIDE OF SITE 2 PROJECT AREA SHOWN



File: C:\USERS\PLASFORDD\ACDC\GCS\HAZEN AND SAWYER\60006-000\_HIGH RISK SEWER MAIN REPAIR\PROJECT FILES\CIVIL\60006-000-C01 Saved by PGLASFORD Save date: 4/11/2025 3:50 PM PLOT DATE: 5/12/2025 12:50 PM BY: PGLASFORD

PROJECT ENGINEER:	N. SHAH		
DESIGNED BY:	A. REEVES		
DRAWN BY:	P. GLASFORD		
CHECKED BY:	S. O'ROURKE		
IF THIS BAR DOES NOT MEASURE 1" THEN DRAWING IS NOT TO FULL SCALE	0 1/2" 1"		
REV	ISSUED FOR	DATE	BY

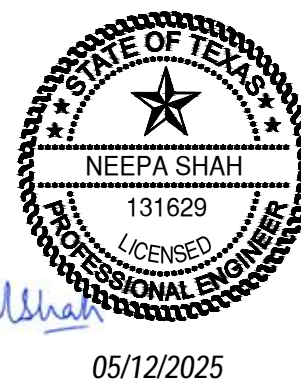

**Hazen**  
HAZEN AND SAWYER  
8150 NORTH CENTRAL EXPRESSWAY  
TOWER II SUITE 700  
DALLAS, TEXAS 75206  
TBPELS Reg. No. F-13618

**MESQUITE TEXAS**  
Real. Texas. Flavor.  
CITY OF MESQUITE  
TEXAS  
SAMUELL PARKS FARMS/SCYENE  
SEWER MAIN REPAIR/REHABILITATION

OVERALL MAP AND SURVEY DATUM  
SITE 1 AND 2

DATE:	MAY 2025
HAZEN NO.:	60006-000
CONTRACT NO.:	2025-073
DRAWING NUMBER:	C001



**LEGEND**

EXISTING SANITARY SEWER (GRAVITY)	SS
PROPOSED SEWER REHABILITATION	SS
100 YR. FLOODPLAIN	SS
FLOODPLAIN ELEVATION BOUNDARY	SS
CREEK CENTERLINE	SS
PROPOSED POINT REPAIR	SS
REMOVE INTERNAL PIPE LAYER	SS

**PLAN**  
1" = 40'

**NOTES:**

- LOCATION OF EX UTILITIES SHOWN ARE FROM CITY GIS FILES. CONTRACTOR TO VERIFY ACTUAL LOCATION OF EXISTING WATER, GAS, STORM, SANITARY SEWER, ELECTRICAL, AND ANY EXISTING FRANCHISE UTILITIES.
- CONTRACTOR TO FIELD VERIFY EXISTING MANHOLE RIM AND SEWER FLOW LINE ELEVATIONS.
- PROPOSED MH RIM ELEVATIONS SHALL BE 3" (MAX.) ABOVE EXISTING GRADE, SEE WW-16.
- REFER TO SPECIFICATION 33 01 30.72 FOR CIPP REHABILITATION.
- REFER TO SPECIFICATION 33 01 30.82 FOR MANHOLE REHABILITATION.
- REFER TO SPECIFICATION 33 01 30.73 FOR POINT REPAIRS.
- REFER TO SPECIFICATION 33 01 30.11 FOR CCTV OF SEWERS.
- REFER TO SPECIFICATION 03 40 10 FOR POLYMER PRECAST CONCRETE MANHOLES.
- CONTRACTOR TO UTILIZE EXISTING SANITARY SEWERS AND MANHOLES FOR BYPASS PUMPING. CONTRACTOR TO SUBMIT BYPASS PUMPING PLAN PRIOR TO ANY PUMPING OPERATIONS.
- CONTRACTOR TO FOLLOW THE NESC AND TEXAS ELECTRICAL CODES FOR MINIMUM DISTANCE TO MAINTAIN FROM THE CONDUCTORS. CONSTRUCTION CREW TO MAINTAIN A MINIMUM OF 20 FT IN ALL DIRECTIONS FROM THE CONDUCTORS (138,000 VOLTS).

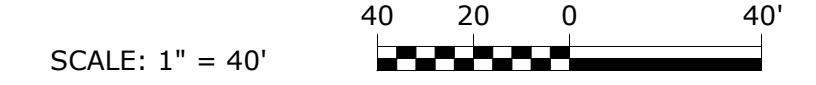

File: C:\USERS\PLASFORDD\ACCD\GCS\HAZEN AND SAWYER\PROJECT FILES\CIVIL\60006-000-C02 Saved by PGLASFORD Save date: 4/11/2025 2:32 PM  
 PLOT DATE: 5/12/2025 12:50 PM BY: PGLASFORD

PROJECT ENGINEER:	N. SHAH		
DESIGNED BY:	A. REEVES		
DRAWN BY:	P. GLASFORD		
CHECKED BY:	S. O'ROURKE		
IF THIS BAR DOES NOT MEASURE 1" THEN DRAWING IS NOT TO FULL SCALE	0 1/2" 1"		
REV	ISSUED FOR	DATE	BY



**Hazen**  
HAZEN AND SAWYER  
8150 NORTH CENTRAL EXPRESSWAY  
TOWER II SUITE 700  
DALLAS, TEXAS 75206  
TBPESL Reg. No. F-13618

**MESQUITE TEXAS**  
CITY OF MESQUITE TEXAS  
SAMUELL PARKS FARMS/SCYENE  
SEWER MAIN REPAIR/REHABILITATION

**SITE 1 - SEWER REHABILITATION PLAN**

DATE:	MAY 2025
HAZEN NO.:	60006-000
CONTRACT NO.:	2025-073
DRAWING NUMBER:	C002

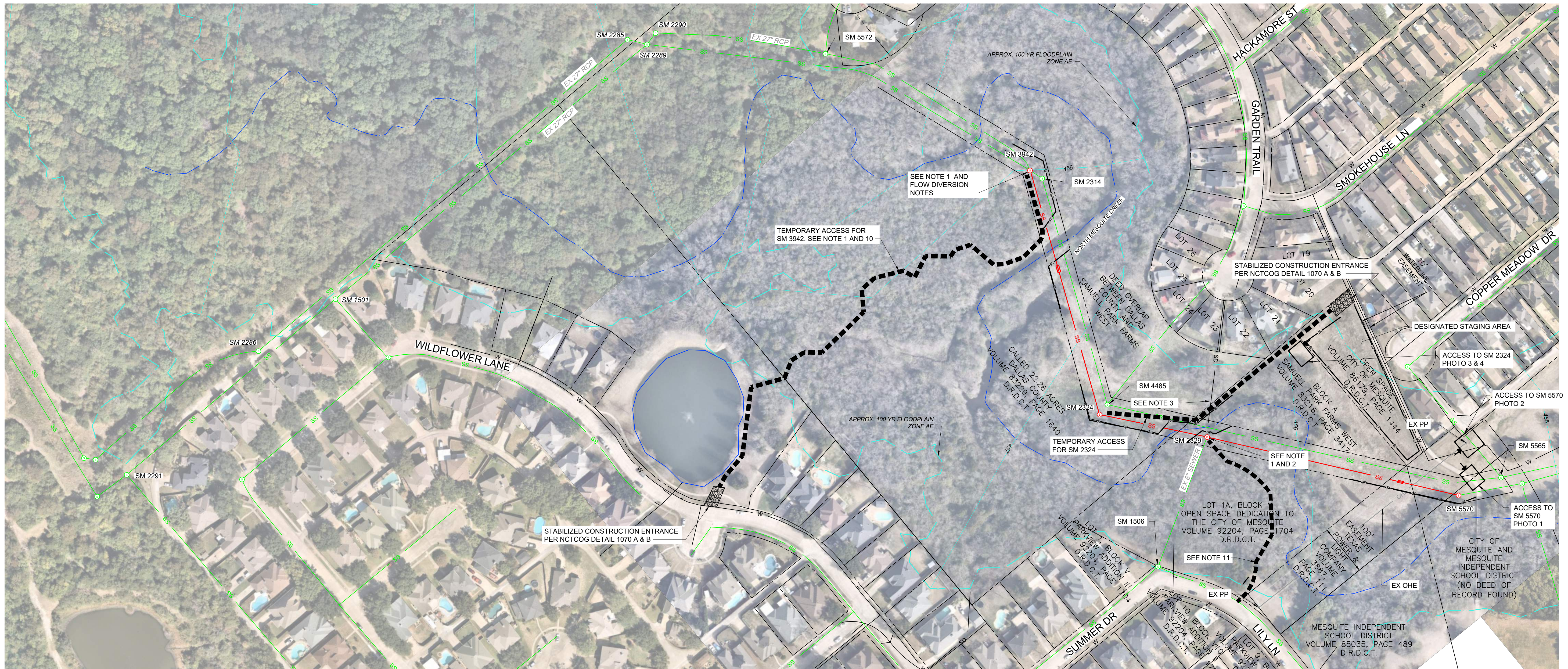

**NOTES:**

- NO DRIVE-IN ACCESS AVAILABLE. WALK-IN AND SMALL EQUIPMENT ACCESS ONLY. TREE REMOVAL IS NOT PERMITTED ALONG THE ACCESS PATH.
- INSTALL SILT FENCE ON DOWNSLOPE SIDES PRIOR TO EXCAVATION PER NCTCOG DETAIL 1020 A & B.
- STORM DRAINAGE DITCH TO REMAIN FUNCTIONAL DURING CONSTRUCTION.
- CONTRACTOR SHALL MAINTAIN DRIVEWAY AND PEDESTRIAN ACCESS THROUGHOUT CONSTRUCTION OPERATION. BLOCKING OF DRIVEWAYS AND PEDESTRIAN WALKWAY IS NOT ALLOWED.
- CONTRACTOR SHALL PROVIDE CONSTRUCTION SAFETY SIGNS FOR PEDESTRIANS.
- CONTRACTOR SHALL STAY WITHIN CITY OR TEMPORARY ACCESS EASEMENT THROUGHOUT CONSTRUCTION OPERATION.
- CONTRACTOR SHALL USE THE CONSTRUCTION ENTRANCE AND ACCESS SHOWN ON THE PLANS.
- CONTRACTOR TO REPAIR ANY DAMAGE INCURRED TO THE CONSTRUCTION ENTRANCE AND ACCESS PATH DUE TO CONSTRUCTION ACTIVITIES TO PRE-CONSTRUCTION CONDITIONS OR BETTER.
- CONTRACTOR TO FOLLOW THE NESC AND TEXAS ELECTRICAL CODES FOR MINIMUM DISTANCE TO MAINTAIN FROM THE CONDUCTORS. CONSTRUCTION CREW TO MAINTAIN A MINIMUM OF 20 FT IN ALL DIRECTIONS FROM THE CONDUCTORS (138,000 VOLTS).
- CONTRACTOR TO NOTIFY AND COORDINATE CONSTRUCTION ACCESS WITH DALLAS COUNTY PRIOR TO START OF CONSTRUCTION.
- NO DRIVE-IN ACCESS AVAILABLE. WALK-IN AND SMALL EQUIPMENT ACCESS ONLY. CONTRACTOR SHALL COORDINATE AND RECEIVE APPROVAL OF FINAL ACCESS PATH PRIOR TO BEGINNING ANY PATH CLEARING.

**FLOW DIVERSION NOTES:**

- FLOW DIVERSION / BYPASS PUMPING IS CONTRACTOR MEANS AND METHODS. THE FOLLOWING NOTES ARE POTENTIAL METHODS THE FLOW COULD BE DIVERTED TO PERFORM THE WORK.
- FOR REPAIR OF SEGMENTS SM3942-SM2324, FLOW COULD BE DIVERTED FROM SM 2289 TO SM 2290 VIA A SEWER PLUG. FLOW COULD BE PUMPED FROM SM 5572 TO SM 2314
- FOR REPAIR OF SEGMENTS SM2324-SM2329 AND SM2329-SM5570, FLOW COULD BE PUMPED FROM SM 5571 TO SM 4485.

**LEGEND**

- EXISTING SANITARY SEWER (GRAVITY) — SS —
- PROPOSED SEWER REHABILITATION — SS —
- 100 YR. FLOODPLAIN —
- FLOODPLAIN ELEVATION BOUNDARY —
- CREEK CENTERLINE —
- CONTOUR —

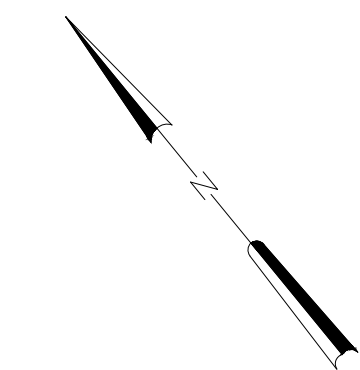

SCALE: 1" = 100'

File: C:\USERS\PLASFORDD\ACCORDS\HAZEN AND SAWYER\PROJECT FILES\CIVIL\60006-000-C03 Saved by PGLASFORD Save date: 4/11/2025 2:44 PM PLOT DATE: 5/12/2025 12:50 PM BY: PGLASFORD

PROJECT ENGINEER:	N. SHAH		
DESIGNED BY:	A. REEVES		
DRAWN BY:	P. GLASFORD		
CHECKED BY:	S. O'ROURKE		
IF THIS BAR DOES NOT MEASURE 1" THEN DRAWING IS NOT TO FULL SCALE	0 1/2" 1"		
REV	ISSUED FOR	DATE	BY

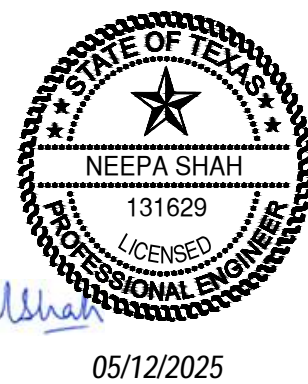

**Hazen**  
HAZEN AND SAWYER  
8150 NORTH CENTRAL EXPRESSWAY  
TOWER II SUITE 700  
DALLAS, TEXAS 75206  
TBPELS Reg. No. F-13618



CITY OF MESQUITE  
TEXAS  
SAMUELL PARKS FARMS/SCYENE  
SEWER MAIN REPAIR/REHABILITATION

SITE 1 - EROSION CONTROL AND ACCESS PLAN

DATE:	MAY 2025
HAZEN NO.:	60006-000
CONTRACT NO.:	2025-073
DRAWING NUMBER:	C003

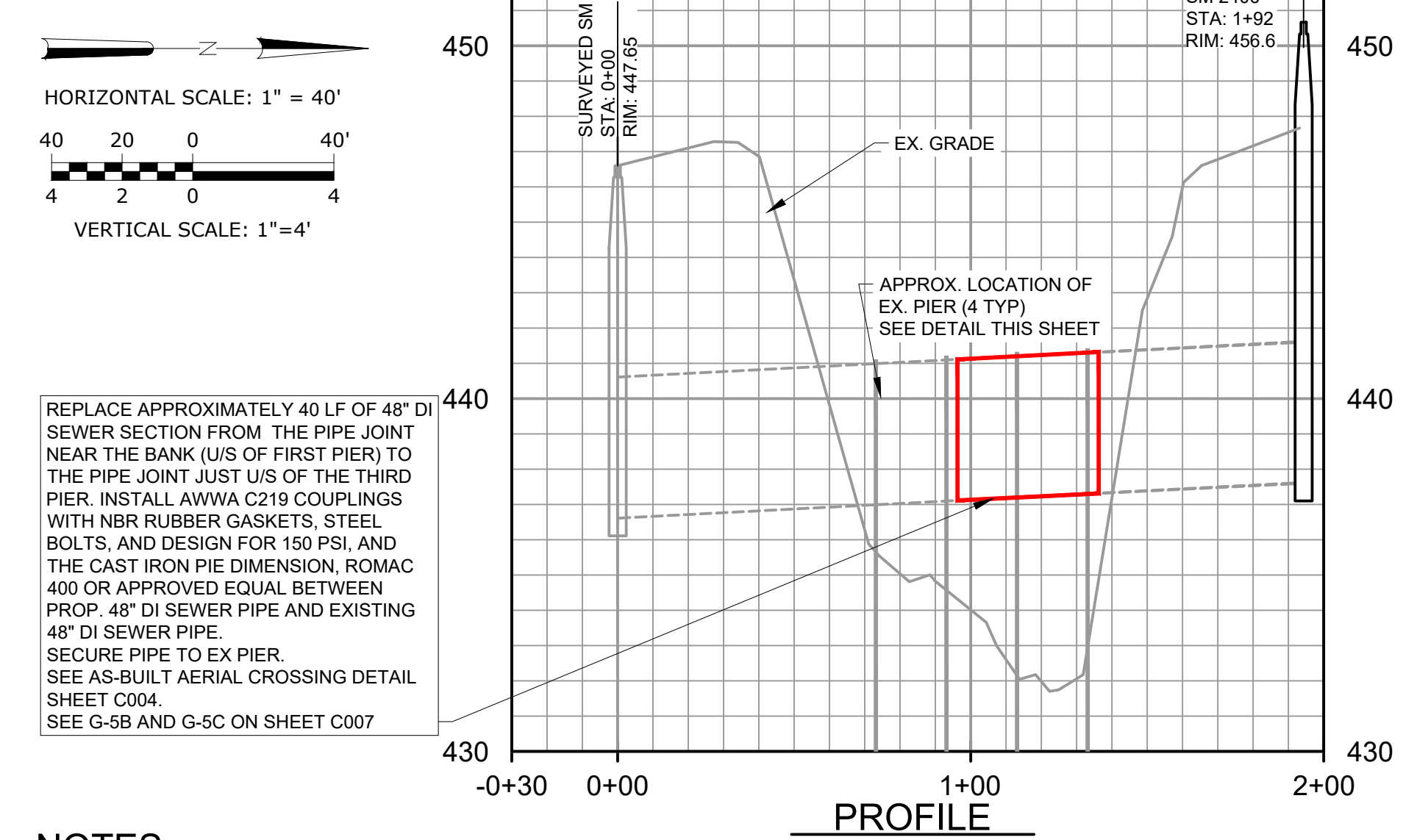
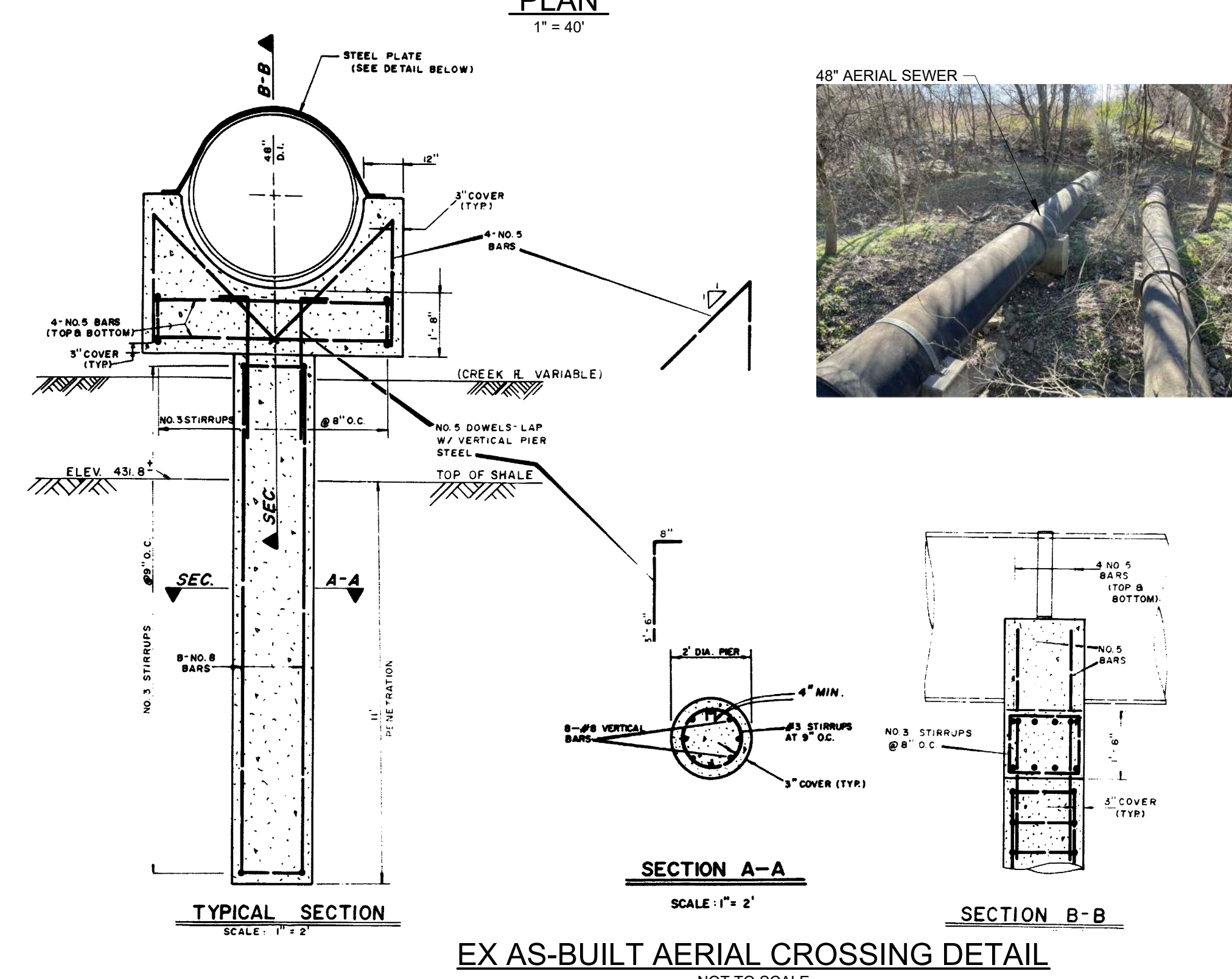
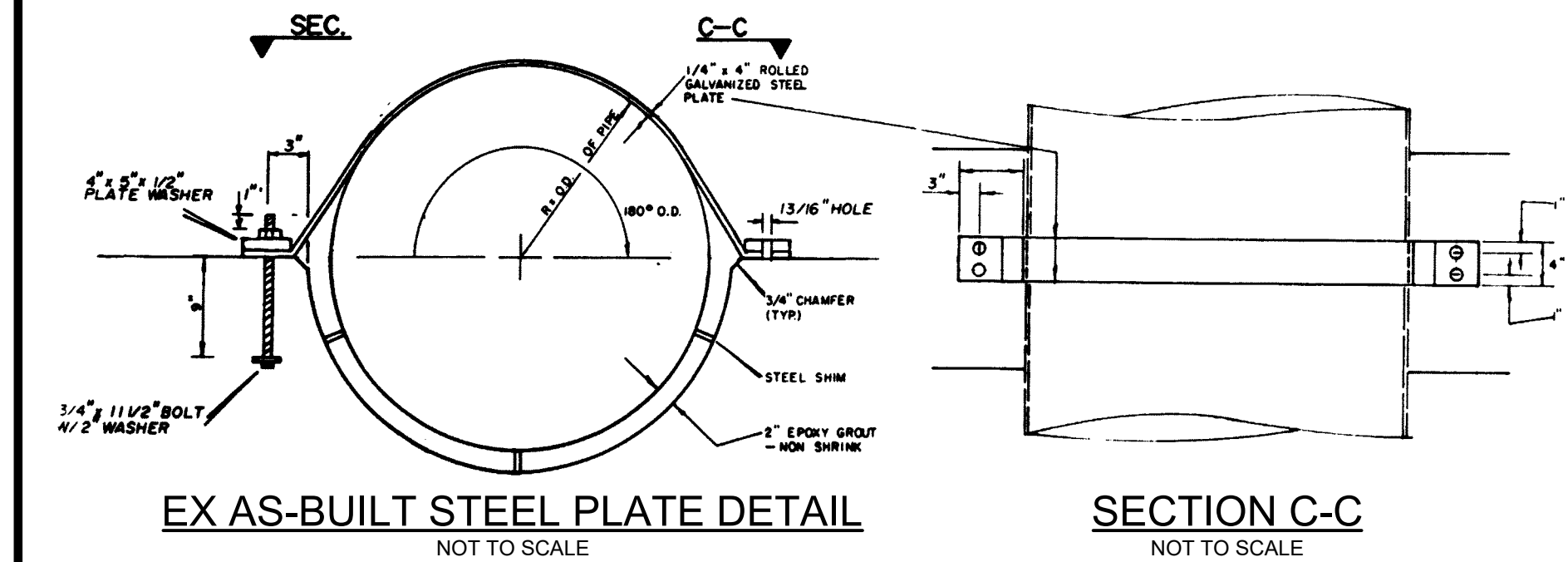
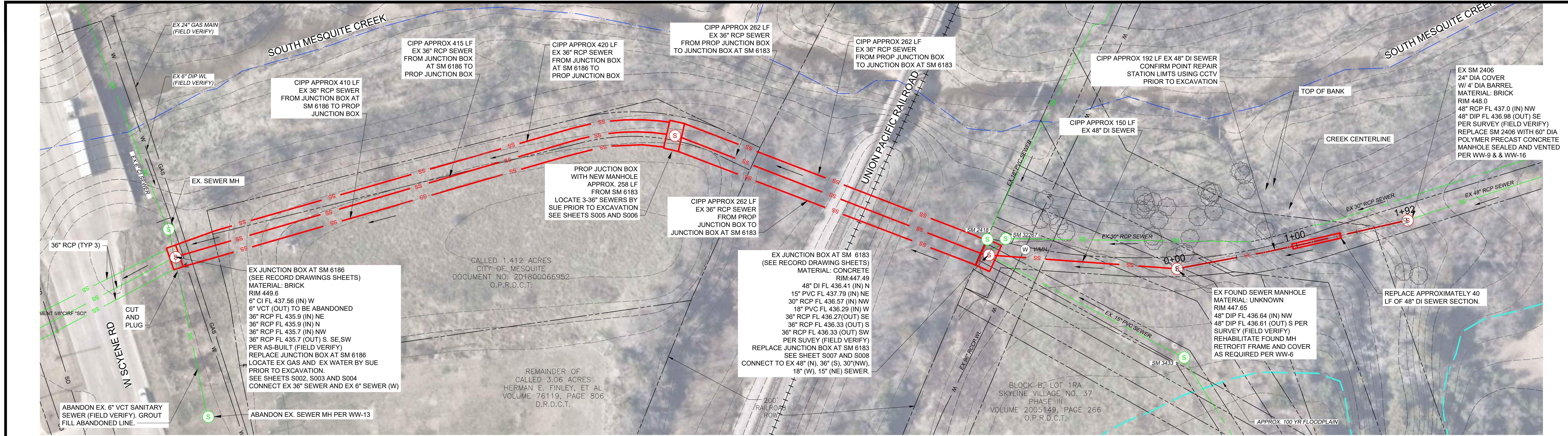

**LEGEND**

EXISTING SANITARY SEWER (GRAVITY)	SS	FLOODPLAIN ELEVATION BOUNDARY	---
PROPOSED SEWER REHABILITATION	SS	CREEK CENTERLINE	---
100 YR. FLOODPLAIN	---	CONTOUR	---

- NOTES:**
- CONTRACTOR TO REPLACE JUNCTION BOXES AT SM 6183 AND SM 6186 PRIOR TO CIPP. CONTRACTOR TO INSTALL PROPOSED JUNCTION BOX PRIOR TO CIPP INSTALLATION.
  - CONTRACTOR TO UTILIZE EXISTING SANITARY SEWERS AND MANHOLES FOR BYPASS PUMPING. CONTRACTOR TO SUBMIT BYPASS PUMPING PLAN PRIOR TO ANY PUMPING OPERATIONS.
  - CONTRACTOR TO SUPPORT PIPE AND PROTECT EXISTING PIERS DURING CONSTRUCTION.
  - LOCATION OF EX UTILITIES SHOWN ARE FROM CITY GIS FILES, SURVEY, AND/OR AS-BUILTS. CONTRACTOR TO VERIFY ACTUAL LOCATION OF EXISTING WATER, GAS, STORM, SANITARY SEWER, ELECTRICAL, AND ANY EXISTING FRANCHISE UTILITIES.
  - FOR PROPOSED JUNCTION BOXES, IF PROPOSED PIPE JOINT IS LOCATED WITHIN 2 FT OF JUNCTION BOX WALL, CONTRACTOR TO ADJUST JUNCTION BOX LOCATION ACCORDINGLY.
  - CONTRACTOR TO FIELD VERIFY EXISTING MANHOLE RIM AND SEWER FLOW LINE ELEVATIONS.
  - CONTRACTOR SHALL NOTIFY UNION PACIFIC RAILROAD (UPRR) AS PER THEIR REQUIREMENTS ON THE CONSTRUCTION & SCHEDULE OF REHABILITATION OF PIPES UNDER THE RAILROAD. CONTRACTOR SHALL COMPLY WITH ALL OF THE REQUIREMENTS OF THE UPRR.
  - PROPOSED MH RIM ELEVATIONS SHALL BE 3" (MAX.) ABOVE EXISTING GRADE. SEE WW-16.
  - REFER TO SPECIFICATION 33 01 30.72 FOR CIPP REHABILITATION. CONTRACTOR TO UTILIZE VINYL ESTER RESIN FOR CIPP FROM SM 2406 TO EX FOUND SEWER MH.
  - REFER TO SPECIFICATION 33 01 30.82 FOR MANHOLE REHABILITATION.
  - REFER TO SPECIFICATION 33 01 30.73 FOR POINT REPAIRS.
  - REFER TO SPECIFICATION 33 01 30.11 FOR CCTV OF SEWERS.
  - REFER TO SPECIFICATION 03 40 10 FOR POLYMER PRECAST CONCRETE MANHOLES.
  - CONTRACTOR SHALL PERFORM THE WORK, TO THE EXTENT FEASIBLE, FROM THE CREEK BANK.
  - CONTRACTOR SHALL NOT PLACE FILL IN THE CREEK.

PROJECT ENGINEER:	N. SHAH		
DESIGNED BY:	A. REEVES		
DRAWN BY:	P. GLASFORD		
CHECKED BY:	S. O'ROURKE		
IF THIS BAR DOES NOT MEASURE 1" THEN DRAWING IS NOT TO FULL SCALE	0 1/2" 1"		
REV	ISSUED FOR	DATE	BY

STATE OF TEXAS  
N. SHAH  
131629  
LICENSED PROFESSIONAL ENGINEER  
05/12/2025

**Hazen**  
HAZEN AND SAWYER  
8150 NORTH CENTRAL EXPRESSWAY  
TOWER II SUITE 700  
DALLAS, TEXAS 75206  
TPELS Reg. No. F-13618

**MESQUITE TEXAS**  
CITY OF MESQUITE TEXAS  
SAMUELL PARKS FARMS/SCYENE  
SEWER MAIN REPAIR/REHABILITATION

**SITE 2 - SEWER REHABILITATION PLAN AND PROFILE**

DATE:	MAY 2025
HAZEN NO.:	60006-000
CONTRACT NO.:	2025-073
DRAWING NUMBER:	C004

File: C:\USERS\PGLASFORD\ACCDGCS\HAZEN AND SAWYER\60006-000-HIGH RISK SEWER MAIN REPAIR\PROJECT FILES\CIVIL\60006-000-C04 Saved by PGLASFORD Save date: 3/28/2025 9:13 AM PLOT DATE: 5/12/2025 12:52 PM BY: PGLASFORD



ACCESS FOR SM 2406 FROM FAMILY CATHEDRAL OF PRAISE PHOTO 1



ACCESS FOR JUNCTION BOX AT SM 6183 PHOTO 3



ACCESS FOR JUNCTION BOX AT SM 6186 FROM W SCYENE ROAD PHOTO 2



ACCESS FOR JUNCTION BOX AT SM 6183 BRIDGE CROSSING PHOTO 4

**NOTES:**

- CONTRACTOR SHALL MAINTAIN PEDESTRIAN ACCESS THROUGHOUT CONSTRUCTION OPERATION.
- CONTRACTOR SHALL PROVIDE CONSTRUCTION SAFETY SIGNS FOR PEDESTRIANS.
- CONTRACTOR SHALL USE THE CONSTRUCTION ENTRANCE AND ACCESS SHOWN ON THE PLANS.
- CONTRACTOR TO REPAIR ANY DAMAGE INCURRED TO THE CONSTRUCTION ENTRANCE AND ACCESS PATH DUE TO CONSTRUCTION ACTIVITIES TO PRE-CONSTRUCTION CONDITIONS OR BETTER.
- CONTRACTOR SHALL INSTALL SILT FENCE ON DOWNSLOPE SIDES PRIOR TO EXCAVATION PER NCTCOG DETAIL 1020 A & B.
- ALL ACCESS AND CONSTRUCTION ACTIVITIES FOR PROPOSED JUNCTION BOXES AND CIPP LINING SHALL BE PERFORMED WITHIN CITY OF MESQUITE PROPERTY / EX EASEMENTS AT ALL TIMES.
- ALL ACCESS ACTIVITIES FOR PROPOSED CONSTRUCTION AND CIPP LINING SHALL REMAIN WITHIN CITY OF MESQUITE PROPERTY OR EXTEMPORARY ACCESS EASEMENTS AT ALL TIMES. CONTRACTOR TO CLEARLY DELINEATE BOUNDARIES PRIOR TO ACCESS AND CONSTRUCTION.
- CONTRACTOR TO INSTALL EROSION CONTROL BLANKETS AT THE AERIAL CROSSING IN THE CREEK AREA PER NCTCOG DETAIL 1160 A & B.
- CONTRACTOR TO NOTIFY AND COORDINATE CONSTRUCTION ACCESS WITH FAMILY CATHEDRAL (CHURCH/SCHOOL/DAYCARE) PRIOR TO START OF CONSTRUCTION.
- EXISTING CONCRETE CULVERT IS NOT ADEQUATE FOR DESIGN TANDEM LOADING. CONTRACTOR SHALL PROVIDE MEANS OF NOT OVERLOADING THE STRUCTURE. DRAWINGS AND CALCULATIONS SHALL BE SIGNED AND SEALED BY A PROFESSIONAL ENGINEER REGISTERED IN THE STATE OF TEXAS.

**FLOW DIVERSION NOTES:**

- FLOW DIVERSION / BYPASS PUMPING IS CONTRACTOR MEANS AND METHODS. THE FOLLOWING NOTES ARE POTENTIAL METHODS THE FLOW COULD BE DIVERTED TO PERFORM THE WORK.
- FOR REPAIR OF SEGMENTS SM2406-SM6183, FLOW COULD BE PUMPED FROM SM 2393 TO SM 2396.
- FOR REPAIR OF SEGMENTS SM6183 TO THE PROPOSED JUNCTION BOX AND TO SM 6186, FLOW COULD BE DAMMED UP AND DIRECTED INTO THE OTHER TWO BARRELS WITH WORK IS COMPLETED ON THE BARREL WITH DIVERTED FLOW.



MATCHLINE THIS SHEET

**LEGEND**

- EXISTING SANITARY SEWER (GRAVITY) — SS —
- PROPOSED SEWER REHABILITATION — SS —
- 100 YR. FLOODPLAIN ---
- CREEK CENTERLINE ---
- CONTOUR ---

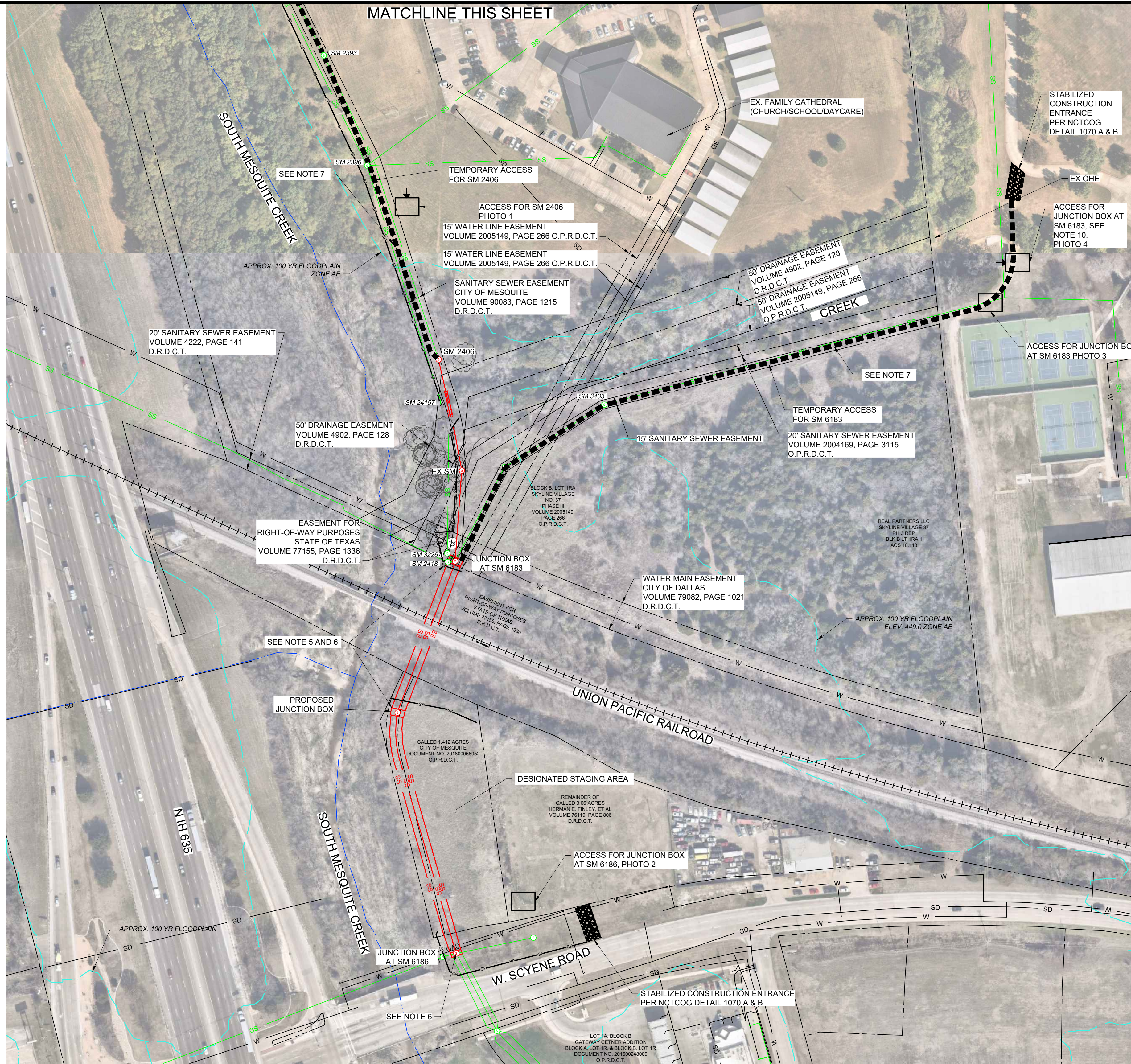

MATCHLINE THIS SHEET

SCALE: 1" = 100'



File: C:\USERS\PLASFORDD\ACCORDS\HAZEN AND SAWYER\06006-000-HIGH RISK SEWER MAIN REPAIR\PROJECT FILES\06006-000-005 Saved by PGLASFORD Save date: 3/28/2025 9:42 AM PLOT DATE: 5/12/2025 2:52 PM BY: PGLASFORD

PROJECT ENGINEER:	N. SHAH
DESIGNED BY:	A. REEVES
DRAWN BY:	P. GLASFORD
CHECKED BY:	S. O'ROURKE
IF THIS BAR DOES NOT MEASURE 1" THEN DRAWING IS NOT TO FULL SCALE	0 1/2" 1"
REV	ISSUED FOR
	DATE
	BY

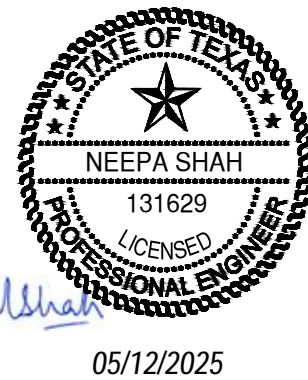

**Hazen**  
HAZEN AND SAWYER  
8150 NORTH CENTRAL EXPRESSWAY  
TOWER II SUITE 700  
DALLAS, TEXAS 75206  
TPELS Reg. No. F-13618

**MESQUITE TEXAS**  
CITY OF MESQUITE TEXAS  
SAMUELL PARKS FARMS/SCYENE  
SEWER MAIN REPAIR/REHABILITATION

SITE 2 - EROSION CONTROL AND ACCESS PLAN

DATE:	MAY 2025
HAZEN NO.:	60006-000
CONTRACT NO.:	2025-073
DRAWING NUMBER:	C005

**Manning's Equation**

$$V = \frac{1.486}{n} R^{2/3} S^{1/2}$$

Where:

- V = Velocity (feet per second)
- n = Manning's roughness coefficient (n = 0.013)
- R = Hydraulic radius of the conduit (R = A/P) (feet)
- A = Cross section flow area (square feet)
- P = Wetted perimeter (feet)
- S = Slope (feet per foot)

6.2.6. Minimum and maximum slopes allowed for wastewater mains, per 30 Texas Administrative Code (TAC) Chapter 217, are shown in Table 6-1. Increasing the main diameter to obtain a flatter slope shall not be allowed unless the maximum design flows will fill the main greater than half-full.

**Table 6-1. Minimum and Maximum Velocity and Slopes**

Size of Main (Inches)	Minimum Slope (percent)	Maximum Slope (percent)
6	0.50	12.35
8	0.33	8.40
10	0.25	6.23
12	0.20	4.88
15	0.15	3.62
Greater than 15	Use Manning's Equation.	

6.2.7. Wastewater Supply and Demand

6.2.7.A. Wastewater systems shall be sized and designed according to the current edition of the City's *Wastewater Collection System Master Plan* and City Engineer requirements.

6.2.7.B. Per the City's *Wastewater Collection System Master Plan*, the average load per person per day is 100 gallons.

6.2.8. *Wastewater Main Sizing* – Required size shall be determined by the Design Engineer and approved by the City Engineer after consulting the current edition of the City's *Wastewater Collection System Master Plan* and considering future extensions to serve the entire drainage basin. The City Engineer may require capacity calculations of the Developer to verify main sizing and adequate capacity prior to approval of the construction plans or building permits.

6.3. Horizontal Alignment and Vertical Alignment

6.3.1. *Horizontal Curves* – Horizontal curves shall be allowed as long as the curve does not exceed 50% of the manufacturers' recommendation for the pipe joint deflection. Manholes shall be located at the point of curvature (PC) and point of tangency (PT) of horizontal curves and have a maximum spacing of 300 feet on a curve. Vertical curves are not allowed.

6.3.2. *Vertical Drops Across Manholes* – To maintain proper flow, manholes for wastewater mains 24-inch and smaller, and horizontal deflections of 15 degrees or larger, shall be designed with a 0.10 foot drop from the elevation of the inlet main to the outlet main.

6.3.3. Depth of Cover

6.3.3.A. The design engineer is responsible for insuring that sufficient depth and grade is maintained to serve all necessary tracts and parcels upstream in the drainage area. The design engineer shall also avoid excessive depths of cover. This is accomplished by calculating a 2% grade for the service line from the centerline of the collection main to the tract or parcel being served.

6.3.3.B. All wastewater mains shall have a minimum cover of 5 feet from the top of pipe to the top of ground or proposed pavement top of curb. Any exception to minimum depths must be approved by the City Engineer.

6.3.4. *Deep Mains* – Wastewater service line connections are not permitted to new wastewater mains exceeding 15 feet of cover as measured from the top of pipe to the top of the proposed ground or pavement top of curb. A parallel wastewater main is required for wastewater service line connections exceeding 15 feet in depth.

6.4. Connections to Existing Wastewater Mains

6.4.1. *Connections at a Manhole* – In accordance with TCEQ requirements, when connecting a proposed main to an existing main at a manhole, the preferred connection should have the elevation of the outfall main level with the top inside elevation of the proposed main.

6.4.2. *Manholes at Service Line Connections* – Manholes are required at any 6-inch, or larger, residential or non-residential service line connection.

6.4.3. *Manholes with Pipe of Different Sizes* – In manholes with pipes of different sizes (diameters), the tops of pipes shall be placed at the same elevation (soffit to soffit). Prior to connecting to the existing main, the new manhole and upstream pipe segment must pass inspection by the City Engineer.

6.4.4. *Service Line Connections* – Service line connections to wastewater mains larger than 15-inches are not allowed unless approved by the City Engineer.

6.5. Manholes

6.5.1. *Manhole Locations* – Manholes shall be placed at all points of change in alignment, grade, size, material, or inside diameter of the wastewater main. In addition, manholes shall be placed at an intersection of two or more wastewater mains, at the end of the main (after the last service), and any locations required to provide accessibility for maintenance. Manholes shall not be located within a residential driveway or access point. Manhole location should not be within the wheel path. Manhole rings and covers should be designed so they do not project in to curb lines, sidewalks, retaining walls, guardrails, or other facilities sharing the same rights-of-way or easement.

6.5.2. *Manhole Spacing* – On wastewater mains, the maximum distance between wastewater manholes shall follow the requirements in Table 6-2.

**Table 6-2. Maximum Manhole Spacing**

Largest Main Size at Manhole	Maximum Manhole Spacing (feet)
6-inch to 15-inch	500
18-inch and larger	800

6.5.3. *Manhole Size and Type* – The minimum manhole diameter and wall thickness shall follow the requirements in Table 6-3.

**Table 6-3. Manhole Size and Wall Thickness**

Condition	Minimum Manhole Diameter	Minimum Wall Thickness
Depth of Manhole less than 15 feet (top of ring to flowline of lowest main) with the largest main entering the manhole less than 15 inches diameter	4 feet	5 inches Pre-Cast
		6 inches Cast-in-Place
Depth of Manhole greater than 15 feet (top of ring to flowline of lowest main) with the largest main entering the manhole less than 15 inches diameter	5 feet	6 inches Pre-Cast
		8 inches Cast-in-Place
All drop manholes (internal drop required) or any manhole with largest main entering 15 inches to 21 inches in diameter	5 feet	6 inches Pre-Cast
		8 inches Cast-in-Place
Manholes with largest main entering 24 inches to 30 inches in diameter	6 feet	8 inches
Larger or deeper mains and other special conditions and situations not covered by above requirements	As required by the City Engineer	As required by the City Engineer

6.5.4. *Drop Manholes* – Drop Manholes shall be installed if there is an incoming main with a vertical drop of more than 2 feet measured from flowline to flowline. All drop manholes shall be internal and conform to the Standard Details. Drop manholes shall have a minimum diameter of 5 feet. Existing manholes that have drops installed may terminate at the drop pipe at the invert ledge.

6.5.5. *Manhole Elevation* – The top of a manhole located within the 100-year floodplain shall be the lesser of a minimum elevation of 1 foot above the ultimate 100-year water surface elevation or 3 feet above adjacent grade. The tops of all other manholes shall be set to the grade of adjacent land or paving. Manholes shall have a concrete apron constructed at grade around all manholes in floodplain.

6.5.6. *Manhole at End of a Main* – In accordance with 30 TAC Chapter 217, all wastewater mains that may be extended at a future date, and laterals, shall end (highest point) with a manhole. The manhole should be placed after the last service.

6.5.7. *Connection Spacing* – To preserve the structural integrity of the manhole, all connections to manholes should provide a minimum 1-foot outside separation between wastewater mains/service lines entering a manhole. All residential service line connections to wastewater mains must maintain a minimum 5-foot separation from the outside edge of any manhole.

6.6. Special Requirements for Wastewater Service Lines

6.6.1. *General* – Design of wastewater service lines should follow the same design procedures as those outlined for mains, except that the information required is reduced in complexity to conform to the reduced function of a service line.

6.6.2. *Connections to a Manhole* – All wastewater service lines that are 6 inches or larger shall connect to a manhole on the wastewater main. Service lines from single-family residences shall not connect to a manhole and shall connect to wastewater main a minimum of 5 feet from the wall of the manhole.

6.6.3. *Private Wastewater Services* – Private wastewater service lines shall be designed, permitted and inspected per the *International Plumbing Code*. Typically, private services are permitted and inspected by the City Building Inspection Division. Delineate on the wastewater plan and profile which segments will be City maintained and which segments will be maintained by the private property owner.

6.6.4. *Single-Family Residential Service Line Size* – 4-inch minimum diameter service lines are required for all single family residential services. Each residence shall be served by an individual service.

6.6.5. *Service Line Location* – Service lines shall be located 10 feet downstream of the water service for the lot (water service generally to be located at the centerline of the lot), and plugged for suitable testing.

6.6.6. Service Line Depth of Cover

6.6.6.A. All wastewater services are to have a minimum cover of 3 feet and a maximum cover of 5 feet as measured at the property line or easement line from the proposed grade to top of pipe.

6.6.6.B. In general, the minimum depth for a wastewater main to serve given property with a 4-inch service line shall be 3 feet plus 2% times the length of the service line to the middle of the structure. Services that are longer than 100 feet from the main and larger buildings may require a deeper service line and may request an exemption by the City Engineer from the maximum cover requirements.

6.6.7. Use of existing wastewater taps shall be governed by the following:

6.6.7.A. The widespread use of PVC pipe for sanitary sewer services in the City began sometime in the mid-1970's.

6.6.7.B. Existing taps made prior to 1975 are likely CI or VCP and must be replaced.

6.6.7.C. Taps made in 1975 and later request the Utility Division to make a TV inspection to determine both material and condition. If TV inspection indicates material is anything other than PVC, replacement shall be required. If TV inspection indicates any defects in the service (pipe out of round, cracks, offset joints, roots, etc.) replacement shall be required.

6.7. *Cleanouts* – When required by the City, show cleanouts on the construction plans at the property line in accordance with the Standard Details.

6.8. Inverted Siphons

6.8.1. An inverted siphon can be designed to a portion of a wastewater main which dips below the hydraulic grade line to avoid any obstructions including, but not limited to a drainage structure, utility, tunnel, or stream. Inverted siphons should be avoided and shall only be considered where all other design alternatives have been evaluated and avoidance or adjustment of the obstructing utility or structure is not feasible, as determined by the City Engineer.

6.8.2. *Siphon Design* – When allowed, a siphon must be designed in accordance with TCEQ requirements, and include the following:

- Two or more barrels;
- Minimum 8-inch diameter main;
- Two manholes with adequate clearance for cleaning with a flushing truck;
- Sufficient head to achieve a velocity of at least 3 feet per second at initial and design flows. The arrangement of inlet and outlet works must divert the normal flow to one barrel and designed such that any barrel can be taken out of service for cleaning;
- Provisions to allow cleaning across each bend with equipment available to the entity in charge of operation and maintenance of the facility; and,
- A design that minimizes nuisance odors.

6.9. *Odor Control Units* – The City Engineer may require the installation of odor control units at force mains, lift stations, and inverted siphons. Odor control units must be designed in accordance with requirements as determined by the City Engineer and be compatible with existing odor control units within the City.

File: C:\USERS\PGLASFORD\ACCD\GCS\HAZEN AND SAWYER\PROJECT FILES\CIVIL\60006-000-HIGH RISK SEWER MAIN REPAIR\PROJECT FILES\CIVIL\60006-000-006 Saved by PGLASFORD Save date: 3/28/2025 9:12 AM PLOT DATE: 5/12/2025 12:59 PM BY: PGLASFORD

PROJECT ENGINEER:	N. SHAH		
DESIGNED BY:	A. REEVES		
DRAWN BY:	P. GLASFORD		
CHECKED BY:	S. O'ROURKE		
IF THIS BAR DOES NOT MEASURE 1" THEN DRAWING IS NOT TO FULL SCALE	0 1/2" 1"		
REV	ISSUED FOR	DATE	BY

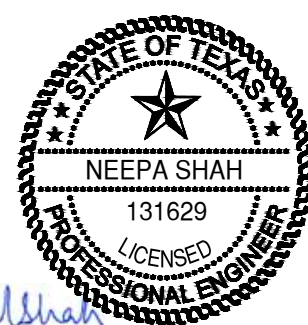

**Hazen**  
HAZEN AND SAWYER  
8150 NORTH CENTRAL EXPRESSWAY  
TOWER II SUITE 700  
DALLAS, TEXAS 75206  
TBPELS Reg. No. F-13618



CITY OF MESQUITE TEXAS  
SAMUELL PARKS FARMS/SCYENE  
SEWER MAIN REPAIR/REHABILITATION

CITY OF MESQUITE  
WASTEWATER DESIGN REQUIREMENTS

DATE:	MAY 2025
HAZEN NO.:	60006-000
CONTRACT NO.:	2025-073
DRAWING NUMBER:	C006

DETAIL NO.	DETAIL NAME	EFFECTIVE DATE
<b>GENERAL</b>		
G-GN	GENERAL NOTES	11/11/2019
G-1	TABLE OF CONTENTS	05/20/2019
G-2	TYPICAL PAVEMENT CUT OVER TRENCH	11/11/2019
G-3	UTILITY BORE	05/20/2019
G-4	CONCRETE ENCASEMENT	05/20/2019
G-5A-C	AERIAL CROSSING	05/20/2019
<b>PAVING</b>		
P-1	EXPANSION JOINTS	11/11/2019
P-2	CONSTRUCTION JOINTS	11/11/2019
P-3	SAWED CONTRACTION & ISOLATION JOINTS	05/20/2019
P-4	STREET JOINTING	05/20/2019
P-5	TYPICAL HEADERS	05/20/2019
P-6	THICKENED CONCRETE EDGE	05/20/2019
P-7	TYPICAL CURB & GUTTER	07/24/2019
P-8	PEDESTRIAN FACILITIES	11/11/2019
P-9	MONOLITHIC NOSE	05/20/2019
P-10	MEDIAN	05/20/2019
P-11	STAMPED CONCRETE MEDIAN PAVEMENT	05/20/2019
P-12A,12B	PERMANENT BARRICADE	05/20/2019
P-13A,13B	LEFT TURN LANE	05/20/2019
P-14	CONCRETE PAVING DETAIL - TYPICAL SECTION	05/20/2019
P-15	CONCRETE SIDEWALK WITH RETAINING WALL	05/20/2019
P-16	CURB RAMP - TYPE A	09/08/2020
P-17	CURB RAMP - TYPE B	09/08/2020
P-18	CURB RAMP - TYPE C	09/08/2020
P-19	CURB RAMP - TYPE D	09/08/2020
P-20	FIRE LANE PAVING	05/20/2019
P-21	FIRE LANE STRIPING	05/20/2019
P-22	ALLEY PAVING	05/20/2019
P-23	ALLEY/STREET INTERSECTION - OFFSET SIDEWALK	05/20/2019
P-24	ALLEY/STREET INTERSECTION - ADJACENT SIDEWALK	05/20/2019
P-25	ALLEY UTILITY LOCATION	05/20/2019
P-26	DRIVEWAY - GENERAL	07/24/2019
P-27	DRIVEWAY - FLARED	05/20/2019
P-28	DRIVEWAY - RADIAL	05/20/2019
P-29	DRIVEWAY - RESIDENTIAL ALLEY	05/20/2019
<b>WATER</b>		
W-GN	GENERAL NOTES - WATER	07/24/2019
W-1	TYPICAL WATER MAIN PIPE EMBEDMENT (NOT UNDER PAVEMENT)	09/08/2020
W-2	TYPICAL WATER MAIN PIPE EMBEDMENT (UNDER PAVING)	11/11/2019
W-3	WATER FLANGED FITTINGS	05/20/2019
W-4	WATER VALVE	05/20/2019
W-5	ABANDONMENT OF VALVE STACK	05/20/2019
W-6	AIR RELEASE VALVE	05/20/2019

W-7	WATER SERVICE	09/08/2020
W-8	TYPICAL UTILITY LOCATIONS	09/08/2020
W-9	FIRE HYDRANT	09/08/2020
W-10	FIRE HYDRANT (STRAIGHT)	05/20/2019
W-11	FIRE HYDRANT (90 BEND)	05/20/2019
W-12	WATER FLANGED FITTINGS	05/20/2019
W-13	FIRE SPRINKLER YARD PIPING	05/20/2019
W-14	REMOTE FDC AND FIRE LINE	05/20/2019
W-15	3" THRU 10" DOMESTIC TURBINE WATER METER ASSEMBLY	05/20/2019
W-16	FIRE HYDRANT BOLLARD	05/20/2019
<b>WASTEWATER</b>		
WW-GN	GENERAL NOTES - WASTEWATER	11/11/2019
WW-1	WASTEWATER EMBEDMENT (NOT UNDER PAVING)	04/13/2020
WW-2	WASTEWATER EMBEDMENT (UNDER PAVING)	04/13/2020
WW-3	WASTEWATER LATERAL	05/20/2019
WW-4	WASTEWATER MAINLINE CLEANOUT	05/20/2019
WW-5	WASTEWATER MANHOLE RING AND COVER	05/20/2019
WW-6	WASTEWATER MANHOLE RING AND COVER (RETROFIT ONLY)	05/20/2019
WW-7	DOUBLE CLEANOUT	05/20/2019
WW-8	SINGLE CLEANOUT	05/20/2019
WW-9	PRECAST MANHOLE	05/20/2019
WW-10	CAST-IN-PLACE MANHOLE	05/20/2019
WW-11	PRECAST DROP MANHOLE	05/20/2019
WW-12	CAST-IN-PLACE DROP MANHOLE	05/20/2019
WW-13	ABANDONED MANHOLE	05/20/2019
WW-14	MANHOLE INVERT AND CONNECTION	05/20/2019
WW-15	MANHOLE BLOCKOUT	05/20/2019
WW-16	MANHOLE VENT	05/20/2019
WW-17	PRECAST FLAT MANHOLE LID	05/20/2019
WW-18	CAST-IN-PLACE FLUSH MANHOLE LID	05/20/2019
WW-19	CAST-IN-PLACE MANHOLE LID	05/20/2019
<b>TRAFFIC</b>		
T-1A,1D	PAVEMENT MARKING	05/20/2019
T-5	JOGGLE BARS & TRAFFIC ARROWS	05/20/2019
T-6	STREET LIGHTING CONDUIT	05/20/2019
T-7	CROSSWALK PAVEMENT MARKING	05/20/2019
T-8	STREET NAME SIGN LAYOUT	05/20/2019
<b>SOLID WASTE</b>		
SW-1A,1B	DUMPSTER ENCLOSURE	05/20/2019
<b>DRAINAGE</b>		
D-1A,1B	5' AND 10' SINGLE RECESSED CURB INLET	05/20/2019
D-2A,2B	15' AND 20' DOUBLE STANDARD CURB INLET	05/20/2019
D-3A,3B	5' AND 10' SINGLE STANDARD CURB INLET	05/20/2019
D-4	CURB INLET DETAILS AND NOTES	05/20/2019
D-5	CURB INLET REINFORCING	05/20/2019
D-6A,6B	STORM DRAIN MANHOLE 4', 5', OR 6' SQUARE	05/20/2019

D-7A,7B	CONCRETE CHANNEL DETAILS	05/20/2019
D8	CONCRETE COLLAR	11/11/2019
D9	STORM DRAIN EMBEDMENT	11/11/2019
<b>FRANCHISE UTILITY</b>		
F-1	FRANCHISE UTILITY PAVEMENT CUT REPLACEMENT	05/20/2019
F-2	TYPICAL FRANCHISE UTILITY LOCATION IN STREET ROW	05/20/2019
F-3	TYPICAL FRANCHISE UTILITY LOCATION IN ALLEY ROW	05/20/2019
F-4	RESERVED FOR FUTURE USE	
F-5A	FRANCHISE UTILITY GENERAL NOTES	04/13/2020
F-5B	FRANCHISE UTILITY GENERAL NOTES	05/20/2019

MESQUITE TEXAS Public Works		GENERAL DESIGN STANDARDS STANDARD DETAILS	
TABLE OF CONTENTS		SCALE: N.T.S.	SHEET: G-1A
		REVISION DATE: 09/08/2020	

MESQUITE TEXAS Public Works		GENERAL DESIGN STANDARDS STANDARD DETAILS	
TABLE OF CONTENTS		SCALE: N.T.S.	SHEET: G-1B
		REVISION DATE: 09/08/2020	

MESQUITE TEXAS Public Works		GENERAL DESIGN STANDARDS STANDARD DETAILS	
AERIAL CROSSING		SCALE: N.T.S.	SHEET: G-5C
		REVISION DATE: 05/17/2022	

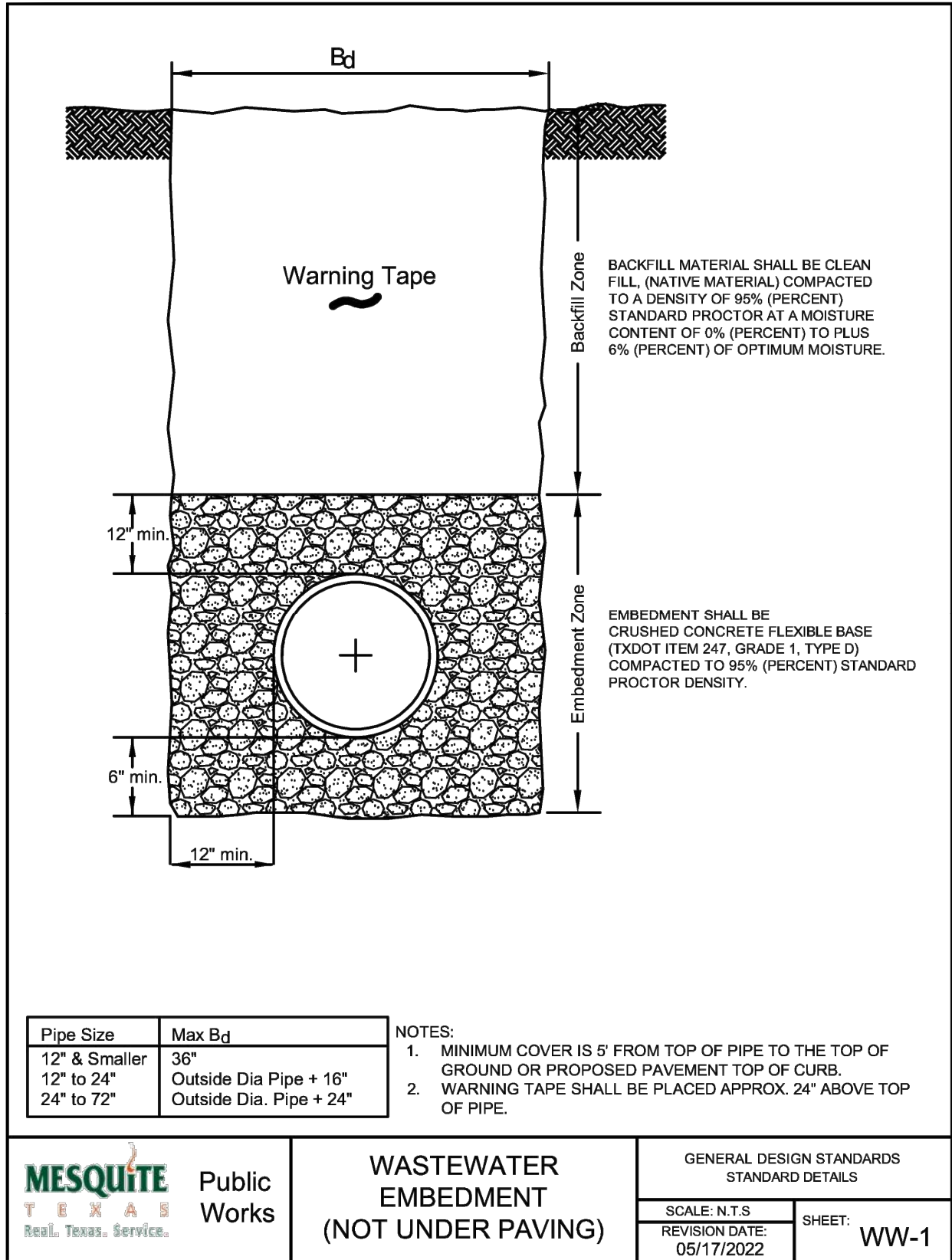

MESQUITE TEXAS Public Works		GENERAL DESIGN STANDARDS STANDARD DETAILS	
WASTEWATER EMBEDMENT (NOT UNDER PAVING)		SCALE: N.T.S.	SHEET: WW-1
		REVISION DATE: 05/17/2022	

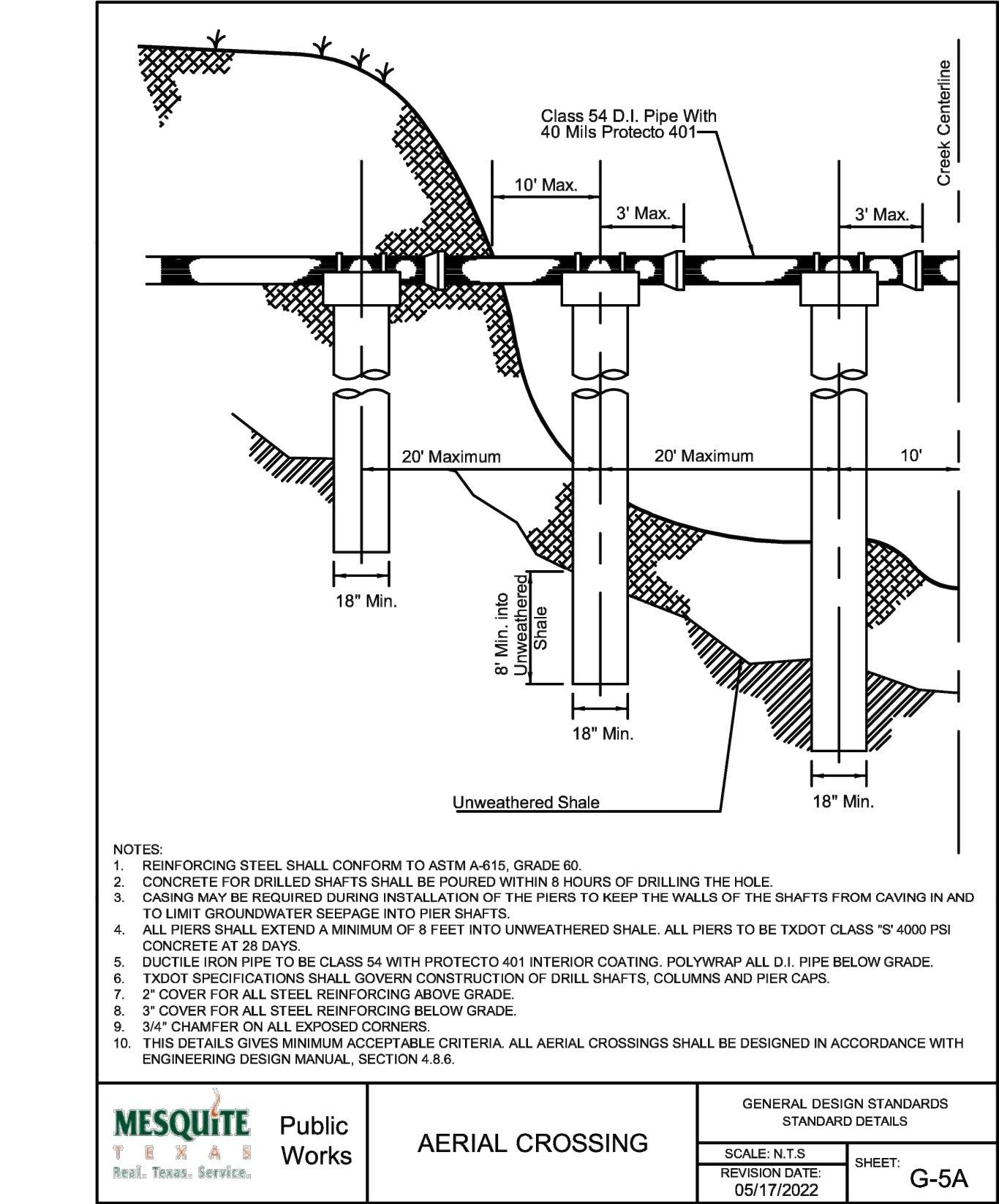

MESQUITE TEXAS Public Works		GENERAL DESIGN STANDARDS STANDARD DETAILS	
AERIAL CROSSING		SCALE: N.T.S.	SHEET: G-5A
		REVISION DATE: 05/17/2022	

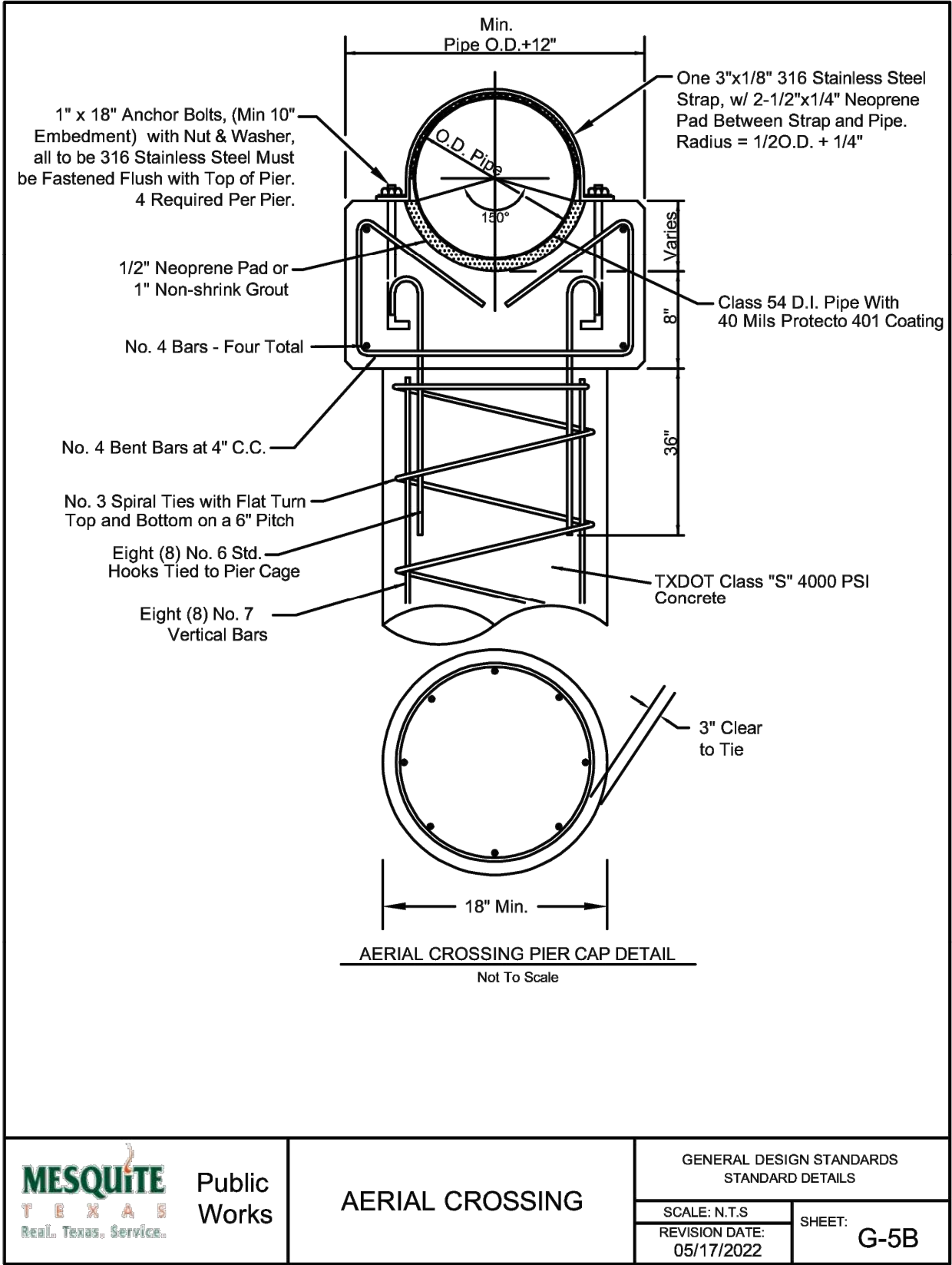

MESQUITE TEXAS Public Works		GENERAL DESIGN STANDARDS STANDARD DETAILS	
AERIAL CROSSING		SCALE: N.T.S.	SHEET: G-5B
		REVISION DATE: 05/17/2022	

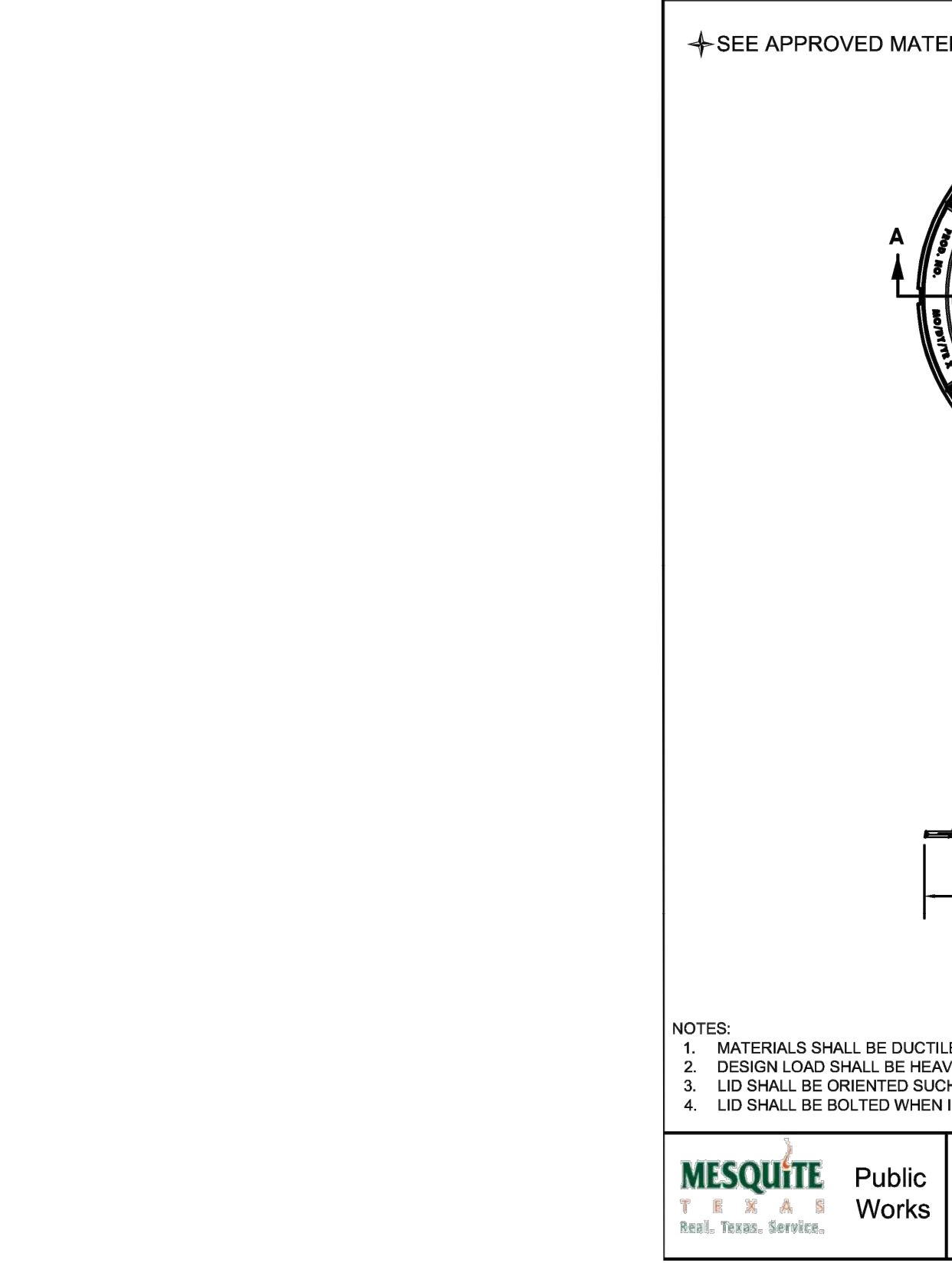

MESQUITE TEXAS Public Works		GENERAL DESIGN STANDARDS STANDARD DETAILS	
WASTEWATER MANHOLE RING AND COVER		SCALE: N.T.S.	SHEET: WW-5
		REVISION DATE: 05/17/2022	

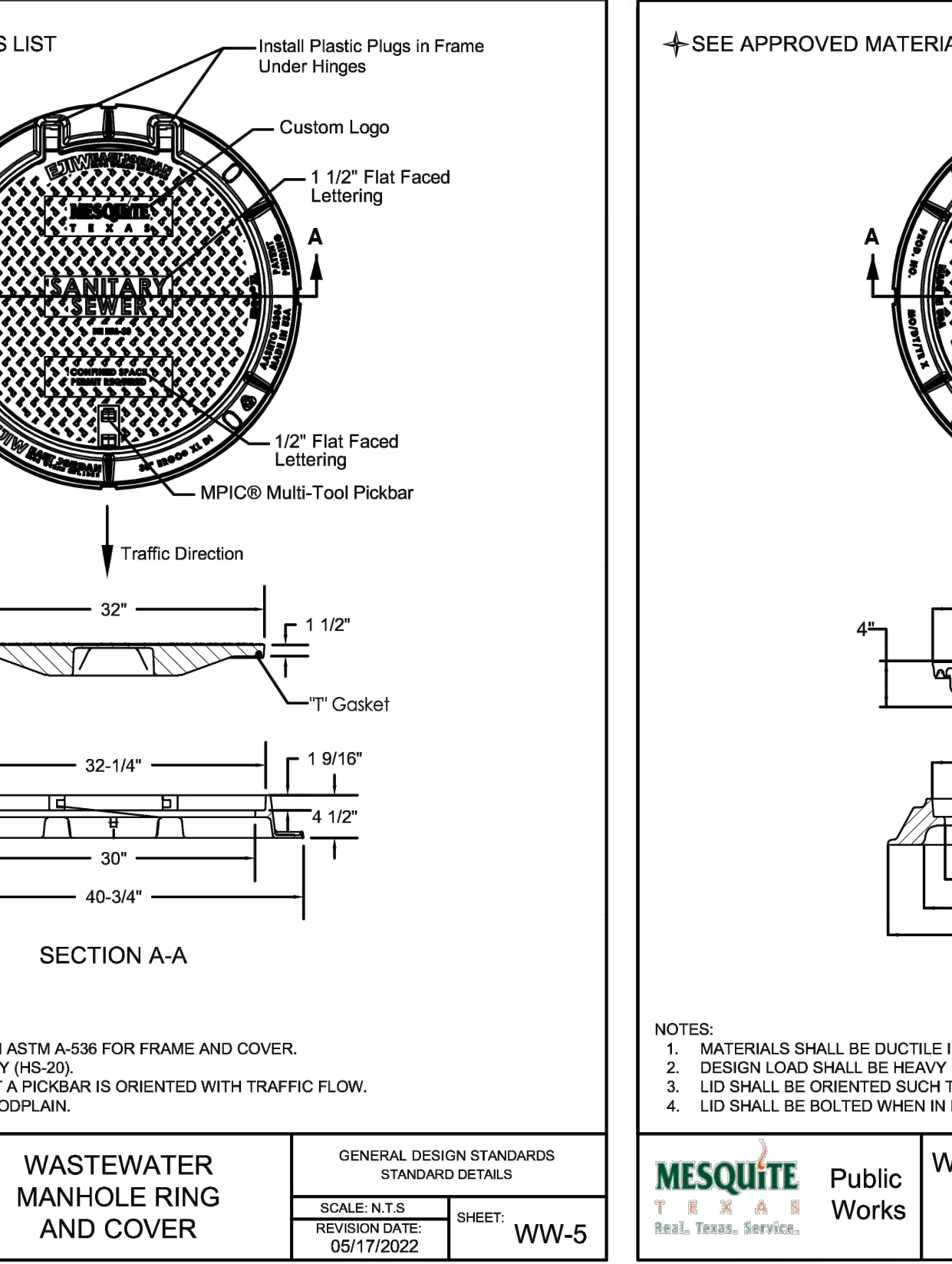

MESQUITE TEXAS Public Works		GENERAL DESIGN STANDARDS STANDARD DETAILS	
WASTEWATER MANHOLE RING AND COVER (RETROFIT ONLY)		SCALE: N.T.S.	SHEET: WW-6
		REVISION DATE: 05/17/2022	

REV	ISSUED FOR	DATE	BY

PROJECT ENGINEER:	N. SHAH
DESIGNED BY:	A. REEVES
DRAWN BY:	P. GLASFORD
CHECKED BY:	S. O'ROURKE
IF THIS BAR DOES NOT MEASURE 1" THEN DRAWING IS NOT TO FULL SCALE	0 1/2" 1"

**Hazen**

Hazen and Sawyer  
8150 NORTH CENTRAL EXPRESSWAY  
TOWER II SUITE 700  
DALLAS, TEXAS 75206  
TBPELS Reg. No. F-13618

**MESQUITE TEXAS** CITY OF MESQUITE TEXAS  
131629  
SAMUELL PARKS FARMS/SCYENE  
SEWER MAIN REPAIR/REHABILITATION

CITY OF MESQUITE  
PUBLIC WORKS DEPARTMENT  
MISCELLANEOUS DETAILS

DATE:	MAY 2025
HAZEN NO.:	60006-000
CONTRACT NO.:	2025-073
DRAWING NUMBER:	C007

File: C:\USERS\PGLASFORD\ACCORDS\HAZEN AND SAWYER\60006-000\_HIGH RISK SEWER MAIN REPAIR\PROJECT FILES\CIVIL\60006-000-C07 Saved by PGLASFORD Save date: 3/28/2025 9:12 AM PLOT DATE: 5/12/2025 2:52 PM BY: PGLASFORD

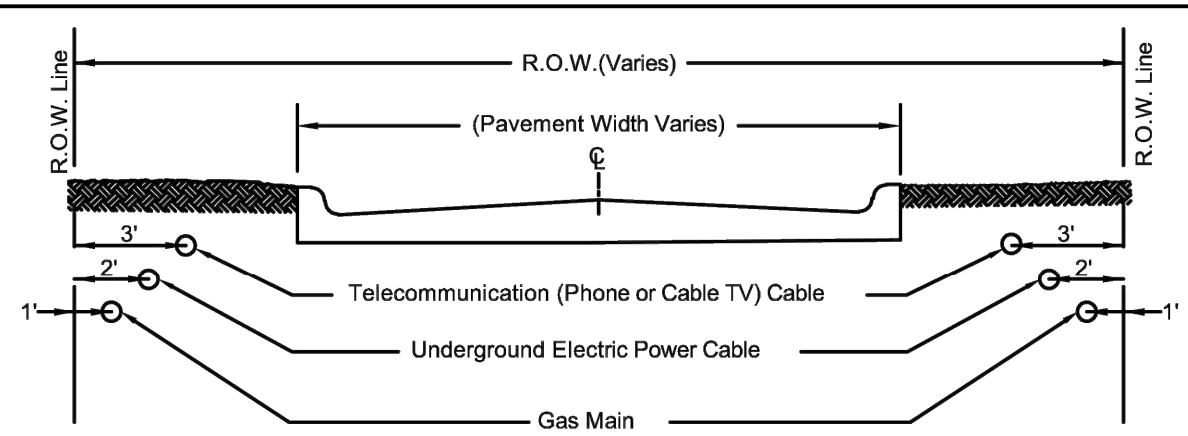

LOCATIONS IN STREET ROW WITH NO OVERHEAD FACILITIES

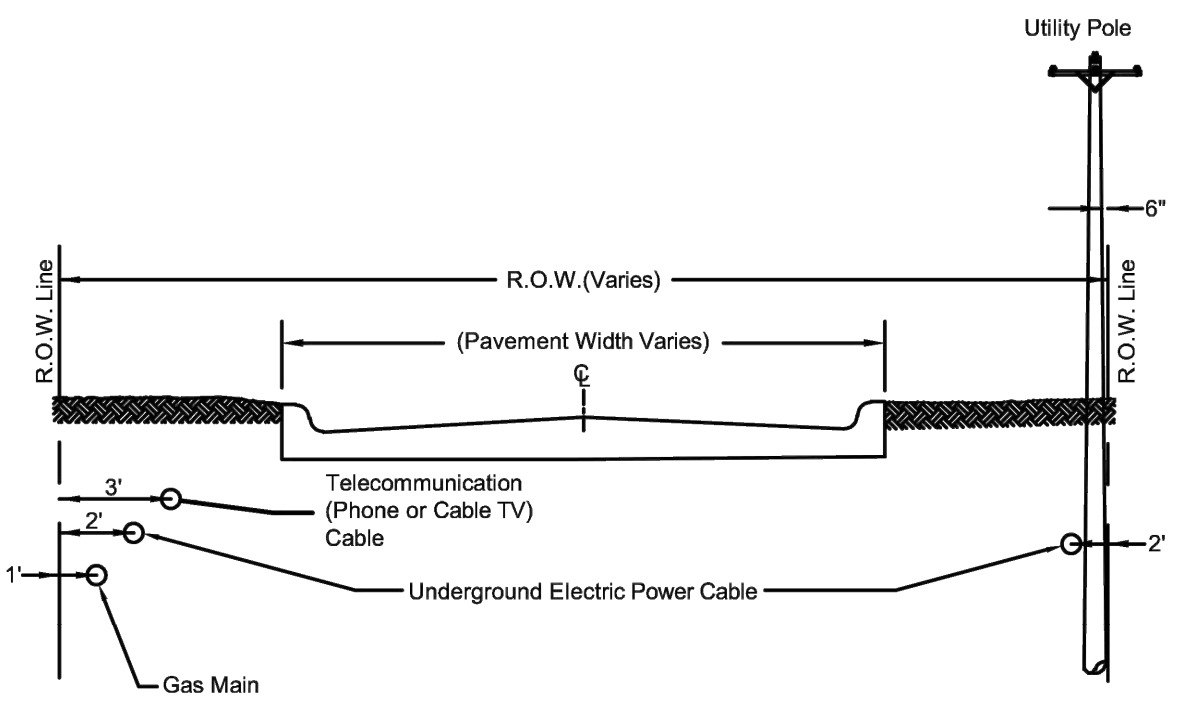

LOCATIONS IN STREET ROW WITH OVERHEAD FACILITIES

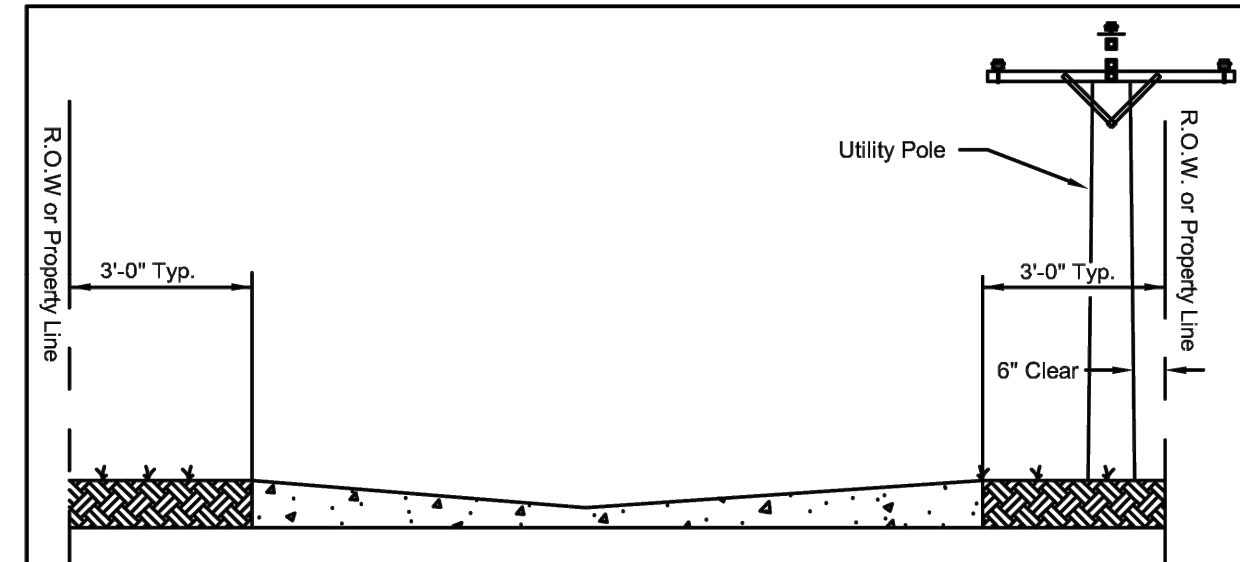

LOCATIONS IN ALLEY ROW WITH OVERHEAD FACILITIES

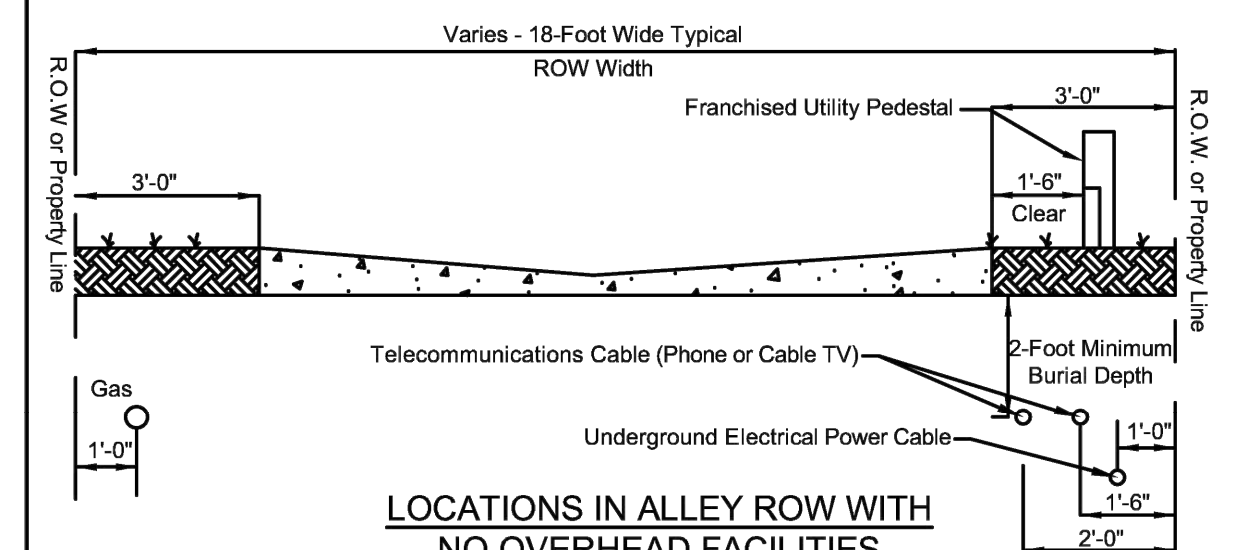

LOCATIONS IN ALLEY ROW WITH NO OVERHEAD FACILITIES

NOTE:  
1. ALL FRANCHISED UTILITIES SHALL HAVE A MINIMUM BURIAL DEPTH OR 24" (TWENTY-FOUR INCHES) BELOW BOTTOM OF PAVING.  
2. GAS SERVICES LINE FOR HOUSE SHALL BE INSTALLED 1'-0" BEYOND ROW/PROPERTY LINE.

**CITY OF MESQUITE - ENGINEERING DIVISION  
UTILITY RIGHT-OF-WAY/EASEMENT USE & CONSTRUCTION PERMIT  
CONDITIONS AND RESTRICTIONS**

THIS PERMIT IS ISSUED IN ACCORDANCE WITH THE MESQUITE CITY CODE, CHAPTER 15, ARTICLE III AND THE APPLICABLE FRANCHISE AGREEMENT BETWEEN THE UTILITY FRANCHISE REQUESTING THE PERMIT AND THE CITY OF MESQUITE AND OTHER APPLICABLE FEDERAL, STATE AND CITY LAWS, REGULATIONS AND ORDINANCES.

**DESIGN AND LOCATION OF FACILITIES:** GENERALLY, FRANCHISED UTILITY CABLES, GUYS, POLES, CONDUIT, ETC. SHALL BE PLACED AS CLOSE TO THE R.O.W. LINE AS PRACTICABLE. SEE ATTACHED DETAIL SHEETS TITLED "TYPICAL UTILITY LOCATION PLAN" FOR STANDARD UTILITY LOCATIONS. PLEASE CONSULT THE CITY PUBLIC WORKS CONSTRUCTION INSPECTOR FOR THE LOCATION WHERE ABOVE GROUND GUYS, POLES, ETC. SHALL BE PLACED.

**CABLE OR FACILITY BURIAL DEPTH:** ALL CONDUCTOR BURIAL DEPTHS SHALL BE IN COMPLIANCE WITH THE NATIONAL ELECTRICAL SAFETY CODE, SECTION 353.D (PUBLISHED BY THE INSTITUTE OF ELECTRICAL AND ELECTRONICS ENGINEERS, INC. (IEEE) AND APPROVED BY THE AMERICAN NATIONAL STANDARDS INSTITUTE (ANSI)). MINIMUM DEPTH FOR VOLTAGES 0 TO 600 VOLTS IS 24-INCHES BELOW BOTTOM OF EDGE OF PAVEMENT FOR STREETS WITH CURB AND GUTTER OR BELOW ROADWAY DITCH FLOWLINE GRADE FOR STREETS WITHOUT CURB AND GUTTER.

**VISIBILITY OBSTRUCTIONS:** NO FACILITY SHALL BE DESIGNED OR INSTALLED WHERE IT CAUSES A SINGLE VISIBILITY OBSTRUCTION OR VIEW OBSTRUCTION. PLEASE CONSULT MESQUITE CITY CODE, CHAPTER 9, ARTICLE X (SECTIONS 9-305 TO 9-308) FOR REQUIREMENTS AND DETAILS.

**ACCESSIBLE ROUTES:** OBSTRUCTIONS OR PROTRUSIONS OF UTILITY POLES, GUY LINES, PEDESTALS, CABINETS OR OTHER UTILITY FACILITIES OVER A SIDEWALK, RAMP, TRAIL OR OTHER TRANSPORTATION FACILITY SO AS TO HINDER OR PREVENT FULL USE OF THE FACILITY OR IMPEDE FULL ACCESS ARE PROHIBITED.

**FRANCHISED UTILITY SIGNAGE AND MARKERS:** ALL FRANCHISED UTILITY SIGNAGE AND MARKERS SHALL BE OF THE FLEXIBLE VERTICAL FIBERGLASS CARSONITE® TYPE AND NO TALLER THAN 48-INCHES ABOVE GRADE (SEE [HTTP://WWW.CARSONITE.COM/UTIL-MARKERS.ASP](http://www.carsonite.com/util-markers.asp)) OR STICKERS & PLAQUES PLACED ON EXISTING FACILITIES SUCH AS POLES, PEDESTALS AND CABINETS OR PLACEMENT MARKER BUTTONS ON CURBS, SIDEWALKS OR PAVEMENT. GENERALLY, SEPARATE SIGNAGE IS DISCOURAGED. SIGNAGE SHALL BE FLEXIBLE SO THAT IT DOES NOT PRESENT A DANGER TO PEDESTRIANS, BICYCLISTS AND MOTORISTS IF THE SIGNAGE IS IMPACTED AT SPEED. METAL POLES AND SIGNS ARE PROHIBITED. THE CITY WILL REQUIRE REMOVAL OF PROHIBITED, DAMAGED OR DILAPIDATED EXISTING SIGNAGE WITHIN 300-FEET OF PROPOSED CONSTRUCTION.

**BOLLARDS:** USE OF BOLLARDS IN CITY RIGHT-OF-WAY IS PROHIBITED. BOLLARDS PRESENT A DANGER TO MOTORISTS, BICYCLISTS AND OTHER USERS OF THE ROW AND EASEMENTS. IF A FACILITY IS IN DANGER OF BEING HIT BY A MOTORIST IT SHOULD BE RELOCATED TO A SAFER LOCATION RATHER THAN BE PROTECTED BY BOLLARDS. IN ADDITION, THE CITY WILL REQUIRE REMOVAL OF EXISTING BOLLARDS WITHIN 300-FEET OF PROPOSED CONSTRUCTION.

**CONSTRUCTION TRAFFIC CONTROL, BARRICADING AND SIGNING:** THE UTILITY COMPANY AND THEIR CONTRACTORS AND SUBCONTRACTORS ARE RESPONSIBLE FOR DESIGN AND IMPLEMENTATION OF A PLAN DURING CONSTRUCTION AND MAINTENANCE OPERATIONS FOR TRAFFIC CONTROL, BARRICADING AND SIGNAGE THAT SHALL AS A MINIMUM MEET THE REQUIREMENTS OF THE MOST CURRENT TEXAS MANUAL OF UNIFORM TRAFFIC CONTROL DEVICES" (MESQUITE CITY CODE SECTIONS 11-104 AND 11-105). NO ALLEY OR STREET SHALL BE CLOSED WITHOUT 48 HOURS NOTICE TO THE ASSIGNED PUBLIC WORKS CONSTRUCTION INSPECTOR.

THE CITY PUBLIC WORKS CONSTRUCTION INSPECTOR WILL PERIODICALLY REVIEW THE PROJECT BARRICADING AND NOTIFY THE UTILITY SUPERVISOR/FOREMAN OF ANY DEFICIENCY OBSERVED.

**ABANDONMENT OF FACILITIES:** ANY CONDUIT/PIPE THAT IS ABANDONED IN PLACE AND IS 6" OR GREATER IN DIAMETER SHALL BE GROUT FILLED.

**TRENCH SAFETY, CONFINED SPACE AND OTHER SAFETY ISSUES:** ALL OSHA GUIDELINES MUST BE FOLLOWED INCLUDING BUT NOT LIMITED TO TRENCH SAFETY, CONFINED SPACE ENTRY, PERSONAL PROTECTIVE EQUIPMENT AND TRAFFIC CONTROL.

THE FRANCHISED UTILITY COMPANY AND SUBCONTRACTOR (IF ANY) ARE RESPONSIBLE FOR DESIGN AND IMPLEMENTATION OF A PLAN TO ENSURE TRENCH SAFETY THAT, AS A MINIMUM SHALL MEET THE REQUIREMENTS OF OSHA STANDARDS AND INTERPRETATIONS, PART 1926, SUBPART P - EXCAVATIONS, TRENCHING, SHORING AND ANY OTHER APPLICABLE FEDERAL, STATE AND CITY LAWS, REGULATIONS AND ORDINANCES. TRENCH SAFETY PLANS SHALL BE SEALED BY A PROFESSIONAL ENGINEER. THE FRANCHISED UTILITY COMPANY AND HIS SUBCONTRACTOR (IF ANY) ARE RESPONSIBLE FOR MAKING A SOIL CLASSIFICATION FOR TRENCH SAFETY DESIGN PURPOSES. IF THE FRANCHISED UTILITY DOES NOT MAKE A DETERMINATION OF SOIL TYPE, ALL INSPECTION SHALL BE BASED ON THE WORST CASE SOIL TYPE (TYPE C). THE FRANCHISED UTILITY COMPANY AND HIS SUBCONTRACTOR (IF ANY) SHALL ALSO DESIGNATE A "COMPETENT PERSON", AS DEFINED BY OSHA TRENCH SAFETY REGULATIONS, TO MAKE AT LEAST A DAILY TRENCH SAFETY INSPECTION.

**FACILITY LOCATES NOTIFICATION PRIOR TO DIGGING:** THE UTILITY COMPANY AND THEIR CONTRACTORS AND SUBCONTRACTORS ARE RESPONSIBLE FOR NOTIFYING THE CITY FOR UTILITY LOCATES 48-HOURS BEFORE COMMENCING DIGGING. IN ADDITION, THE UTILITY COMPANY AND THEIR CONTRACTORS AND SUBCONTRACTORS ARE RESPONSIBLE FOR NOTIFYING THE CITY OF MESQUITE WATER UTILITIES DISPATCH OFFICE FOR LOCATIONS OF WATER AND SANITARY SEWER MAINS AND NOTIFICATION OF THE TRAFFIC SUPERINTENDENT FOR LOCATION OF TRAFFIC SIGNAL CONDUITS AND CONDUCTORS A MINIMUM OF 48-HOURS BEFORE COMMENCING DIGGING. SEE CITY OF MESQUITE CONTACT LIST FOR PHONE NUMBERS AND OTHER CONTACT INFORMATION.

**PAVEMENT CUTS:** NO PAVEMENT SHALL BE CUT OR REPAIRED WITHOUT PRIOR NOTIFICATION AND INSPECTION BY THE ASSIGNED PUBLIC WORKS CONSTRUCTION INSPECTOR.

**ALL PAVEMENT CUTS SHALL BE BACKFILLED TO BOTTOM OF REPLACEMENT PAVEMENT WITH RECYCLED CRUSHED CONCRETE FLEXIBLE BASE (PER TxDOT ITEM 247, GRADE 1, TYPE D) TO PREVENT FUTURE SETTLEMENT. ALL BACKFILL SHALL BE COMPACTED TO 95% STANDARD PROCTOR. PAVEMENT CUTS ON PAVEMENT LESS THAN 5-YEARS OLD SHALL REPLACE THE ENTIRE PANEL OR AS REQUIRED BY THE CITY PUBLIC WORKS CONSTRUCTION INSPECTOR. DETAILS FOR REPAIR OF PAVEMENT CUTS ARE AVAILABLE FROM THE CITY ENGINEERING DIVISION WEBSITE AT: [HTTP://WWW.CITYOFMESQUITE.COM/ENGINEERING/FRANCHISEUTILITY.PHP](http://www.cityofmesquite.com/engineering/franchiseutility.php)**

**NOISE AND ALLOWABLE WORKING HOURS:** NOISE FROM CONSTRUCTION AND ALLOWABLE WORKING HOURS ARE REGULATED BY SECTIONS 10-66 TO 10-77 OF THE MESQUITE CITY CODE. ALLOWABLE WORKING HOURS ARE BETWEEN 7:00 AM AND 10:00 P.M., MONDAY THROUGH SATURDAY. NO WORK IS ALLOWED ON SUNDAY WITHOUT SPECIFIC WRITTEN PERMISSION OF THE CITY ENGINEER. PLEASE CONSULT THE CITY PUBLIC WORKS CONSTRUCTION INSPECTOR WITH ANY QUESTIONS ON THESE ISSUES.

**CONSTRUCTION INSPECTION:** THE CITY PUBLIC WORKS CONSTRUCTION INSPECTOR SHOULD BE NOTIFIED PRIOR TO ANY TRENCH BACKFILLING OR PAVEMENT REPAIR WITHIN A CITY R.O.W. OR EASEMENT SO THAT A PROPER INSPECTION CAN BE MADE. IF CITY INSPECTION IS REQUIRED OUTSIDE NORMAL WORKING HOURS THE FRANCHISED UTILITY AND HIS SUBCONTRACTOR WILL BE RESPONSIBLE FOR PAYING THE CITY CONSTRUCTION INSPECTOR'S OVERTIME WAGE PLUS BENEFITS. THE CITY CONSTRUCTION PUBLIC WORKS INSPECTOR WILL BE HAPPY TO ANSWER ANY QUESTIONS CONCERNING CURRENT CITY STANDARDS AND REQUIREMENTS. SEE PERMIT OR ATTACHED AREA MAP TO DETERMINE RESPONSIBLE INSPECTOR.

**RESTORATION OF PROPERTY:** PER THE MESQUITE CITY CODE, ANY PUBLIC OR PRIVATE PROPERTY OR PAVING DISTURBED BY THE FRANCHISED UTILITY AND HIS SUBCONTRACTOR (IF ANY) SHALL BE RESTORED TO A CONDITION AS GOOD OR BETTER THAN WHAT EXISTED PRIOR TO CONSTRUCTION. THIS INCLUDES REPLACING DISTURBED OR DAMAGED SOD IN PARKWAYS OR ALLEYS, REPAIR OF IRRIGATION SYSTEMS AND REPLACEMENT OF DAMAGED PAVEMENT.

**EMERGENCY WORK (PERMIT REQUIRED WITHIN TWO WORKING DAYS):** PER THE MESQUITE CITY CODE, EMERGENCY WORK CAN PROCEED AS NEEDED TO MAINTAIN & RESTORE EXISTING SERVICE TO CUSTOMERS ON THE CONDITION THAT A PERMIT SHALL BE OBTAINED FROM THE CITY WITHIN TWO (2) WORKING DAYS AFTER THE START OF THE EMERGENCY WORK.

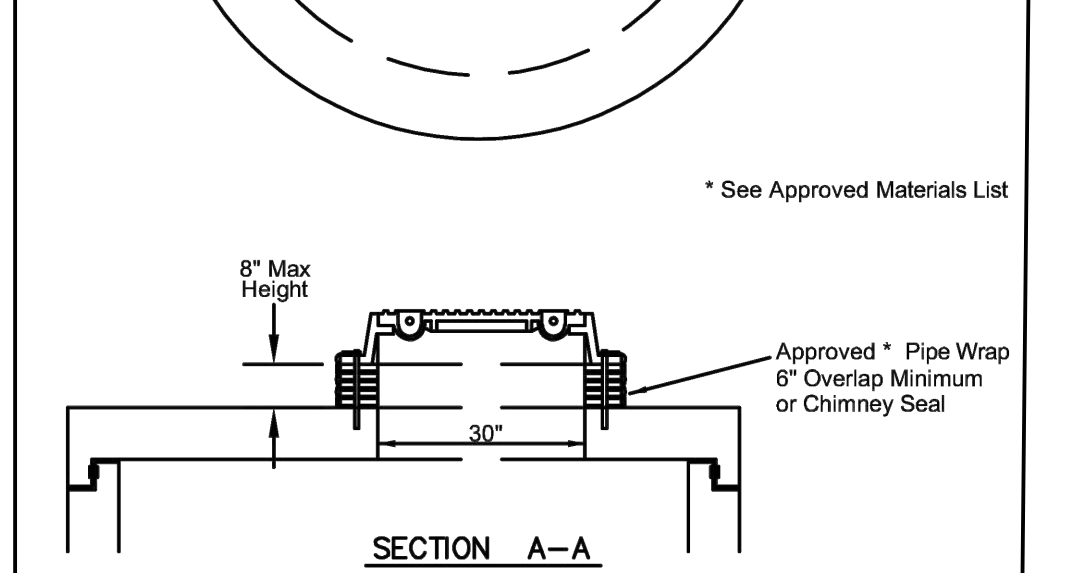
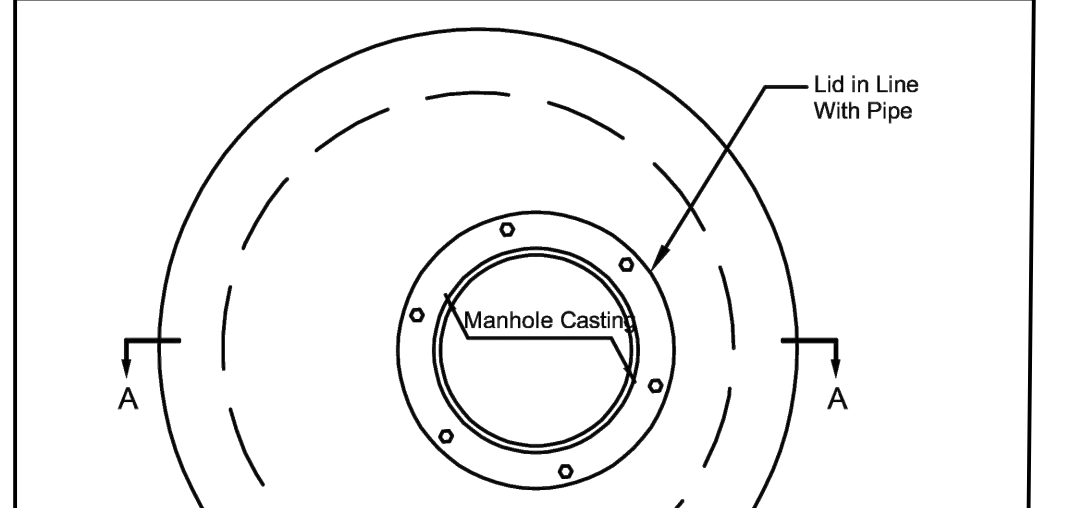

	Public Works	TYPICAL UTILITY LOCATIONS IN STREET ROW	GENERAL DESIGN STANDARDS STANDARD DETAILS	
			SCALE: N.T.S.	SHEET: F-2
			REVISION DATE: 05/20/2019	

	Public Works	TYPICAL UTILITY LOCATIONS IN ALLEY ROW	GENERAL DESIGN STANDARDS STANDARD DETAILS	
			SCALE: N.T.S.	SHEET: F-3
			REVISION DATE: 05/20/2019	

	Public Works	FRANCHISE UTILITY GENERAL NOTES	GENERAL DESIGN STANDARDS STANDARD DETAILS	
			SCALE: N.T.S.	SHEET: F-5A
			REVISION DATE: 04/13/2020	

	Public Works	FRANCHISE UTILITY GENERAL NOTES	GENERAL DESIGN STANDARDS STANDARD DETAILS	
			SCALE: N.T.S.	SHEET: F-5B
			REVISION DATE: 05/20/2019	

	Public Works	PRECAST FLAT MANHOLE LID	GENERAL DESIGN STANDARDS STANDARD DETAILS	
			SCALE: N.T.S.	SHEET: WW-17
			REVISION DATE: 05/17/2022	

NOTES:  
1. MANHOLE FLAT LIDS MUST BE LOAD RATED FOR HS-20 LOADINGS.  
2. SEE PRECAST MANHOLE DETAIL FOR ADDITIONAL REQUIREMENTS.  
3. ALTERNATE: RING AND COVER MAY BE CAST IN TO THE LID PER DETAIL WW-19.

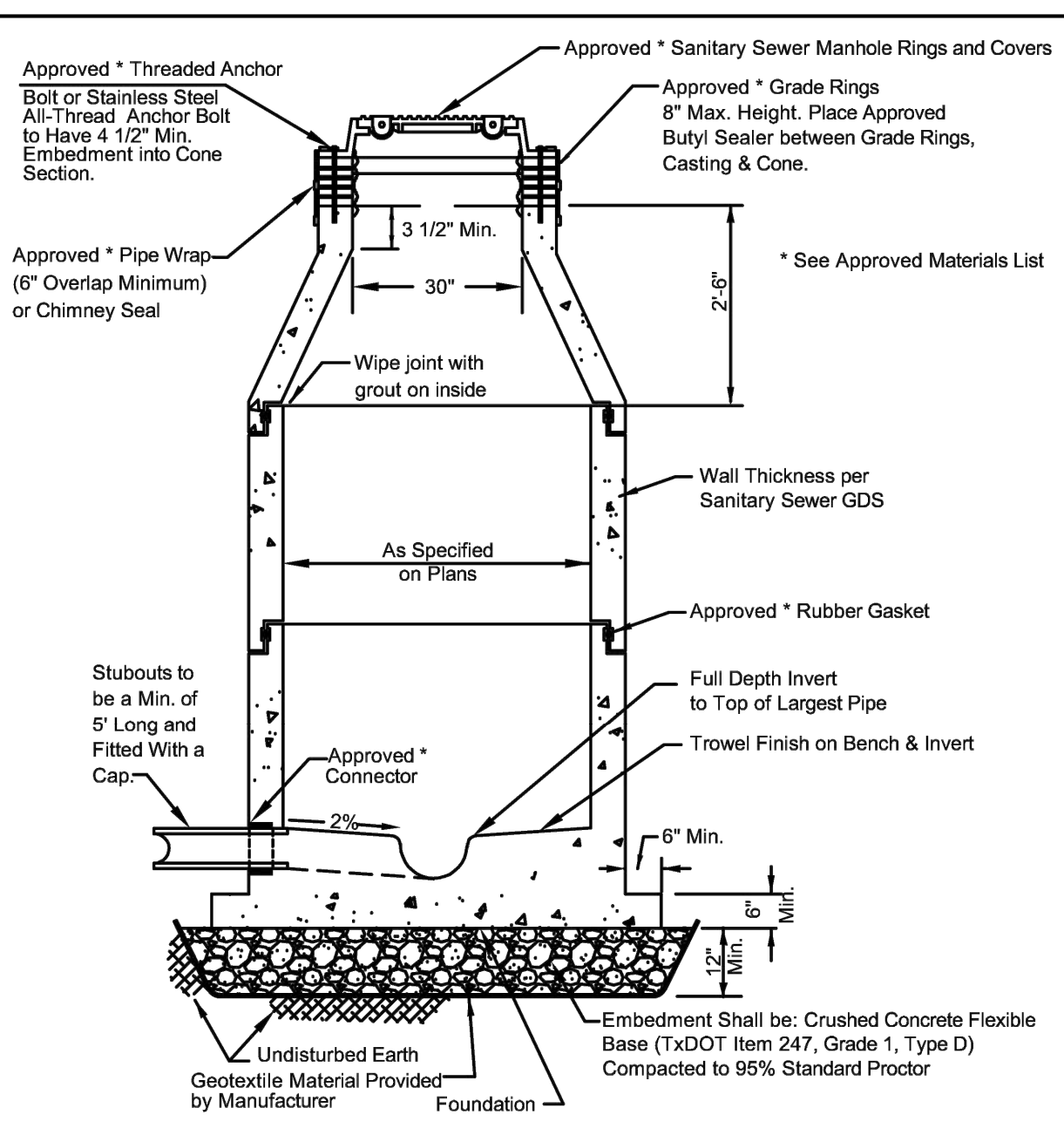

NOTES:  
1. CAST-IN-PLACE MANHOLES ARE STANDARD. PRECAST MANHOLES SHALL BE CONSTRUCTED ONLY WITH APPROVAL OF CITY ENGINEER.  
2. PRECAST RISER SHALL CONFORM TO REQUIREMENTS OF ASTM C-478.  
3. LIFTING HOLES NOT PERMITTED.  
4. NO STEPS ALLOWED.

	Public Works	PRECAST MANHOLE	GENERAL DESIGN STANDARDS STANDARD DETAILS	
			SCALE: N.T.S.	SHEET: WW-9
			REVISION DATE: 05/17/2022	

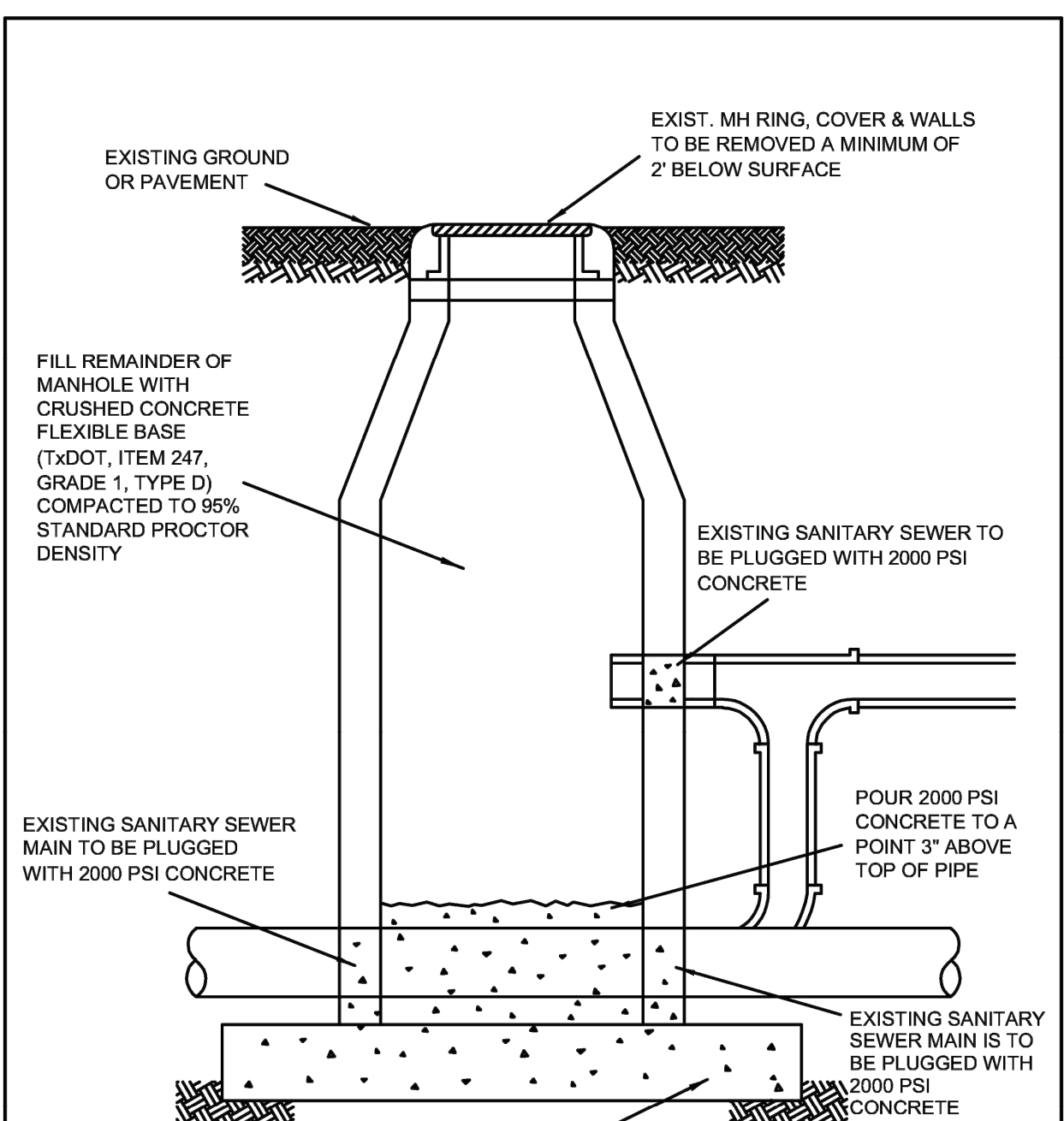

	Public Works	ABANDONED MANHOLE	GENERAL DESIGN STANDARDS STANDARD DETAILS	
			SCALE: N.T.S.	SHEET: WW-13
			REVISION DATE: 05/17/2022	

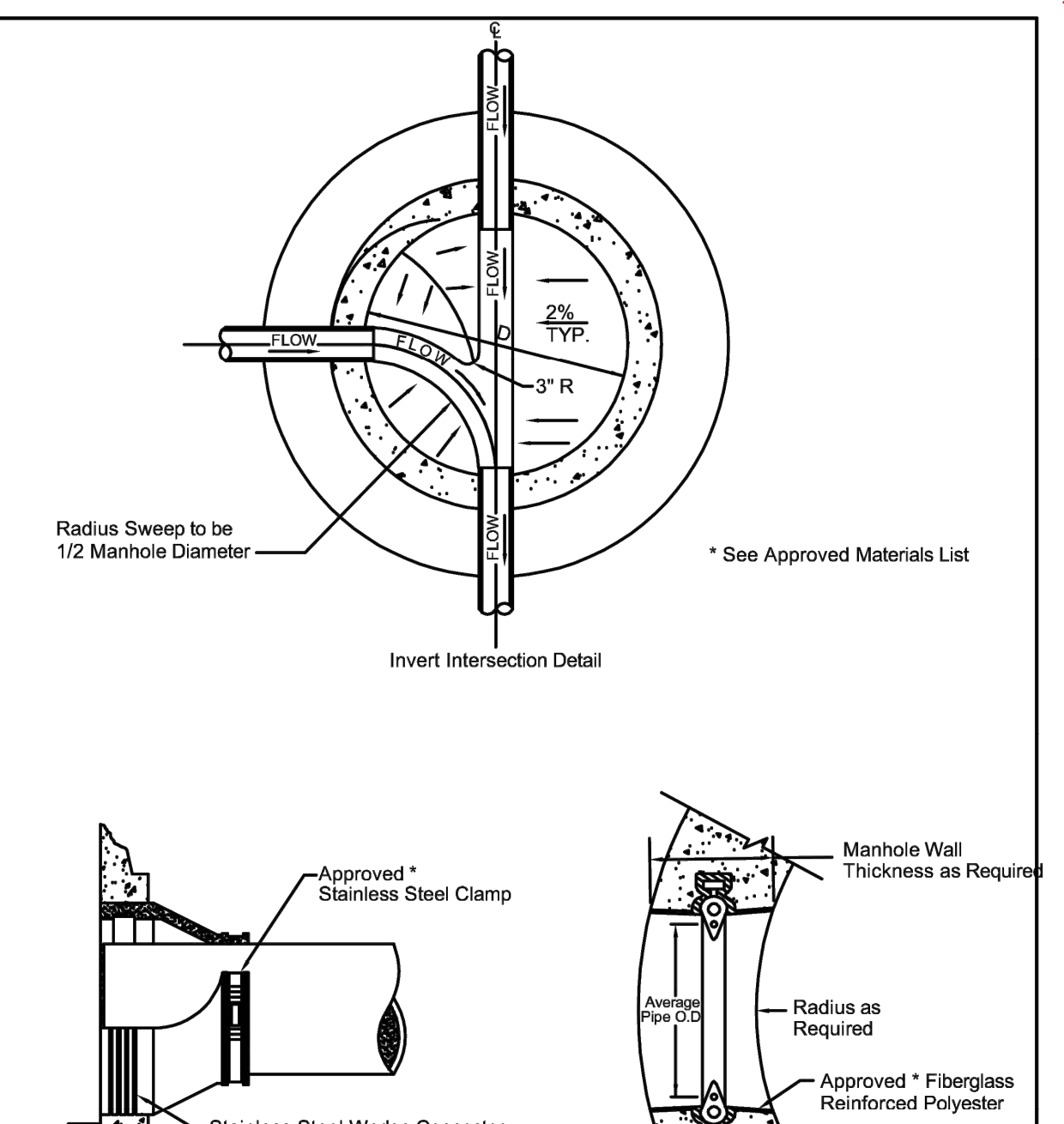

	Public Works	MANHOLE INVERT AND CONNECTION	GENERAL DESIGN STANDARDS STANDARD DETAILS	
			SCALE: N.T.S.	SHEET: WW-14
			REVISION DATE: 05/17/2022	

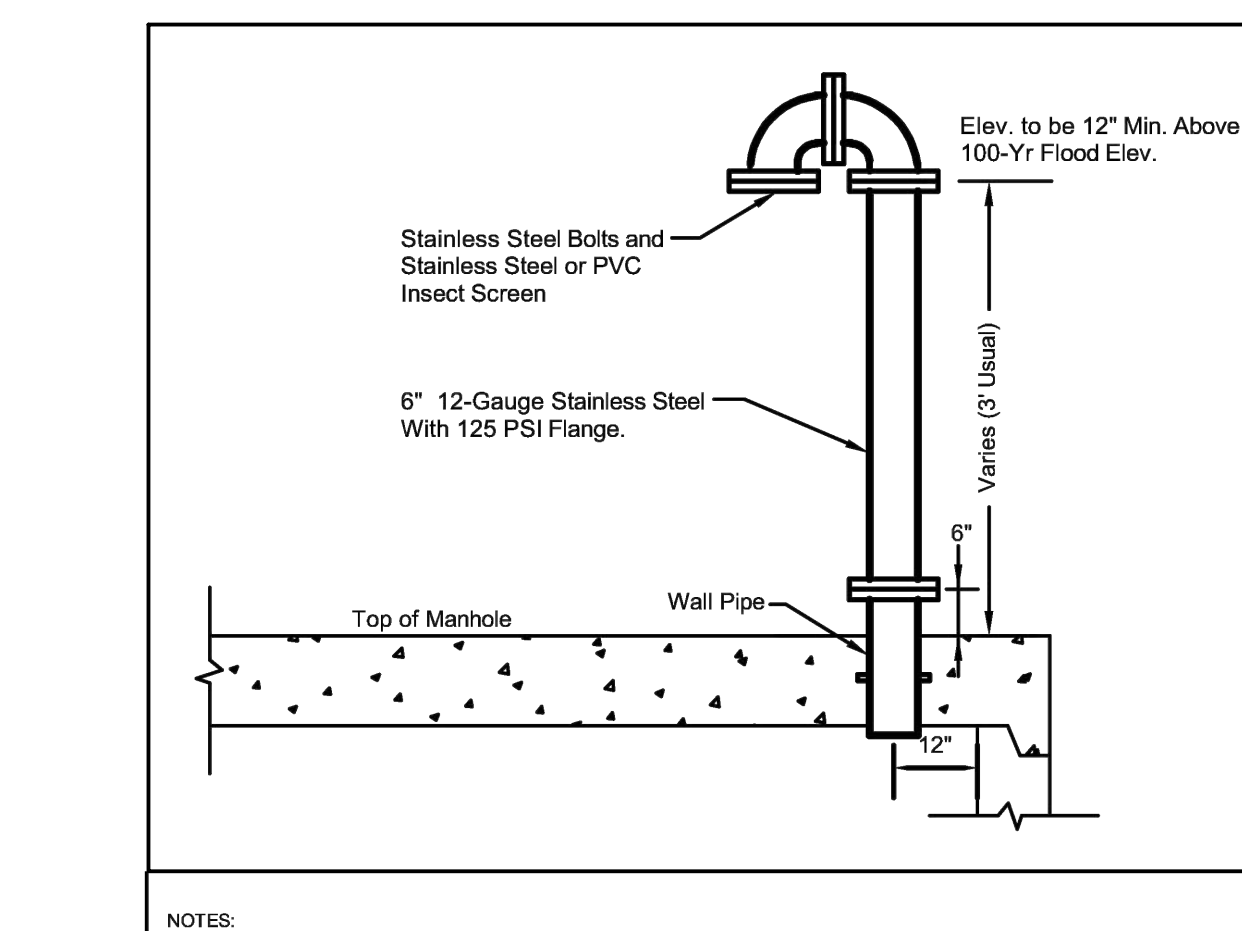

NOTES:  
1. USE ONLY WHEN SPECIFIED ON PLANS.  
2. CHARCOAL CANISTER REQUIRED.

	Public Works	MANHOLE VENT	GENERAL DESIGN STANDARDS STANDARD DETAILS	
			SCALE: N.T.S.	SHEET: WW-16
			REVISION DATE: 05/20/2019	

PROJECT ENGINEER:	N. SHAH		
DESIGNED BY:	A. REEVES		
DRAWN BY:	P. GLASFORD		
CHECKED BY:	S. O'ROURKE		
IF THIS BAR DOES NOT MEASURE 1" THEN DRAWING IS NOT TO FULL SCALE	0 1/2" 1"		
REV	ISSUED FOR	DATE	BY

HAZEN AND SAWYER  
 8150 NORTH CENTRAL EXPRESSWAY  
 TOWER II SUITE 700  
 DALLAS, TEXAS 75206  
 TBPELS Reg. No. F-13618

CITY OF MESQUITE TEXAS  
 SAMUELL PARKS FARMS/SCYENE  
 SEWER MAIN REPAIR/REHABILITATION

DATE: MAY 2025  
 HAZEN NO.: 60006-000  
 CONTRACT NO.: 2025-073  
 DRAWING NUMBER: C008  
 CITY OF MESQUITE  
 PUBLIC WORKS DEPARTMENT  
 WASTEWATER DETAILS

File: C:\USERS\PGLASFORD\ACCDGCS\HAZEN AND SAWYER\60006-000\_HIGH RISK SEWER MAIN REPAIR\PROJECT FILES\CIVIL\60006-000-C08-A\_Saved by PGLASFORD Save date: 3/28/2025 9:13 AM  
 PLOT DATE: 5/12/2025 2:53 PM BY: PGLASFORD

**GENERAL STRUCTURAL NOTES**

- G-1 THESE NOTES ARE GENERAL AND SUPPLEMENT THE SPECIFICATIONS. THESE NOTES APPLY TO THE ENTIRE PROJECT UNLESS MODIFIED OR NOTED OTHERWISE IN THE CONTRACT DOCUMENTS.
- G-2 STANDARD DETAILS SHALL BE USED WHEN REFERRED TO OR WHEN NO MORE RESTRICTIVE OR DIFFERENT DETAILS ARE SHOWN ON THE DRAWINGS.
- G-3 DESIGN IS IN ACCORDANCE WITH AND CONSTRUCTION SHALL COMPLY WITH THE PROVISIONS OF THE 2018 INTERNATIONAL BUILDING CODE WITH LOCAL AMENDMENTS. THE DESIGN LOADS AND OTHER DESIGN VALUES GIVEN IN NOTES G-4 THROUGH G-8 WERE USED FOR DESIGN OF STRUCTURES UNLESS NOTED OTHERWISE ON THE DRAWINGS.
- G-4 LIVE LOADS:  
-ALL STAIRWAYS, LANDINGS AND PLATFORMS ARE DESIGNED FOR A LIVE LOAD = 100 PSF UNLESS NOTED OTHERWISE.  
-TOP SLABS ARE DESIGNED FOR A LIVE LOAD = 300 PSF
- G-5 WIND DESIGN CRITERIA:  
  
BASIC DESIGN WIND SPEED (V) = 111 MPH  
ALLOWABLE STRESS DESIGN WIND SPEED (V<sub>asd</sub>) = 86 MPH  
WIND EXPOSURE =C
- G-6 ALL DIMENSIONS INDICATED FOR EXISTING STRUCTURES SHALL BE VERIFIED BY FIELD MEASUREMENT. ALL DIMENSIONS THAT ARE CONTROLLED BY OR RELATED TO EQUIPMENT SHALL BE VERIFIED BY THE CONTRACTOR WITH THE MANUFACTURER SHOP DRAWINGS PRIOR TO CONSTRUCTION.
- G-7 THE CONTRACTOR IS RESPONSIBLE FOR VERIFYING ALL EXISTING INFORMATION IN THE FIELD AS REQUIRED FOR NEW WORK.
- G-8 IF A CONFLICT IS FOUND BETWEEN DIFFERENT PORTIONS OF THE CONTRACT DOCUMENTS, THE CONTRACTOR SHALL NOTIFY THE ENGINEER IMMEDIATELY. CONTINUED CONSTRUCTION OF THE AREA IN CONFLICT SHALL BE AT THE CONTRACTOR'S OWN RISK UNTIL THE CONFLICT IS RESOLVED.
- G-9 EQUIPMENT ANCHOR SIZES, TYPES, EMBEDMENT AND PATTERNS SHALL BE VERIFIED WITH THE MANUFACTURER. ALL ANCHOR PATTERNS SHALL BE TEMPLATED TO INSURE ACCURACY OF PLACEMENT.
- G-10 STRUCTURAL DRAWINGS SHALL BE USED IN COORDINATION WITH THE DRAWINGS OF ALL OTHER DISCIPLINES AND MANUFACTURER'S SHOP DRAWINGS.
- G-11 STRUCTURES HAVE BEEN DESIGNED FOR OPERATIONAL LOADS ON THE COMPLETED STRUCTURE. DURING CONSTRUCTION, THE STRUCTURES SHALL BE PROTECTED BY BRACING AND TEMPORARY SUPPORTS WHEREVER EXCESSIVE CONSTRUCTION LOADS MAY OCCUR. OVERSTRESSING OF ANY STRUCTURAL ELEMENT IS PROHIBITED.
- G-12 IF CONTRACTOR DESIRES TO TEMPORARILY PLACE OR MOVE LOADS ON OR ADJACENT TO EXISTING STRUCTURES OR UTILITIES DURING CONSTRUCTION PROCESS, CONTRACTOR IS EXCLUSIVELY RESPONSIBLE FOR MAINTAINING STRUCTURAL INTEGRITY AND AVOIDING OVERSTRESSING AND DAMAGING EXISTING STRUCTURES AND UTILITIES. CONTRACTOR SHALL SUBMIT STRUCTURAL CALCULATIONS AND DRAWINGS VERIFYING THAT PROPOSED CONSTRUCTION (INCLUDING APPLICATION OF TEMPORARY CONSTRUCTION LOADS) WILL NOT OVERSTRESS OR DAMAGE EXISTING STRUCTURES AND UTILITIES. DRAWINGS AND CALCULATIONS SHALL BE SEALED BY A PROFESSIONAL ENGINEER CURRENTLY REGISTERED IN THE STATE OF TEXAS.
- G-13 NO BACKFILL SHALL BE PLACED AGAINST ANY SUBSTRUCTURE WALLS UNLESS ALL ADJACENT SUPPORTING ELEMENTS HAVE ACHIEVED DESIGN STRENGTH, OR WALLS HAVE BEEN PROPERLY BRACED, AND IN ANY CASE NOT SOONER THAN 28 DAYS AFTER THE PLACING OF CONCRETE UNLESS APPROVED BY THE ENGINEER. SUPPORTING ELEMENTS SHALL INCLUDE ADJACENT WALLS, SLABS, BEAMS AND COLUMNS.
- G-14 LEAKAGE TESTING OF HYDRAULIC STRUCTURES SHALL NOT BEGIN UNTIL ALL STRUCTURAL ELEMENTS HAVE REACHED THE SPECIFIED MINIMUM CONCRETE STRENGTH. BACKFILL SHALL NOT BE PLACED AROUND ANY HYDRAULIC STRUCTURE UNTIL THE LEAKAGE TEST HAS BEEN COMPLETED UNLESS APPROVED BY THE ENGINEER.

**FOUNDATIONS**

- F-1 CONCRETE (CAST-IN-PLACE) NOTES APPLY TO FOUNDATIONS.
- F-2 ALLOWABLE SOIL BEARING PRESSURE: 1500 PSF
- F-3 MINIMUM DEPTH FROM ADJACENT FINISHED GRADE TO BOTTOM OF FOUNDATION =12 INCHES.
- F-4 STRUCTURES ARE DESIGNED FOR THE 100-YEAR FLOOD ELEVATION OF 450.00

**PRECAST CONCRETE**

- PC-1 POLYMER PRECAST CONCRETE MANHOLES SHALL BE DESIGNED IN ACCORDANCE WITH SPECIFICATION SECTION 03 40 00.
- PC-2 POLYMER PRECAST CONCRETE MANHOLE SHOP DRAWINGS SHALL BE SIGNED AND SEALED BY A PROFESSIONAL ENGINEER CURRENTLY REGISTERED IN THE STATE OF TEXAS.

**CONCRETE (CAST-IN-PLACE)**

- C-1 DESIGN OF CONCRETE ELEMENTS INCLUDING WALLS, FORMED SLABS, BEAMS, AND COLUMNS IS IN ACCORDANCE WITH ACI 318 (CODE REQUIREMENTS FOR STRUCTURAL CONCRETE) AND 350 (CODE REQUIREMENTS FOR ENVIRONMENTAL ENGINEERING CONCRETE STRUCTURES).
- C-2 CONCRETE STRENGTH CLASSES (28-DAY COMPRESSIVE STRENGTH):  
  - A) CLASS A1 CONCRETE (4,500 PSI): NORMAL WEIGHT STRUCTURAL CONCRETE TO BE USED IN ALL STRUCTURES QUALIFYING AS ENVIRONMENTAL CONCRETE STRUCTURES THAT ARE DESIGNED IN ACCORDANCE WITH ACI 350 INCLUDING PUMP STATIONS, TANKS, BASINS, PROCESS STRUCTURES, AND ANY STRUCTURES CONTAINING FLUID OR PROCESS CHEMICALS OR OTHER MATERIALS USED IN TREATMENT PROCESS.
  - B) CLASS B CONCRETE (3,000 PSI): NORMAL WEIGHT STRUCTURAL CONCRETE USED FOR DUCT BANK ENCASUREMENTS, CATCH BASINS, FENCE AND GUARD POST EMBEDMENT, CONCRETE FILL, AND OTHER AREAS WHERE SPECIFICALLY NOTED ON CONTRACT DRAWINGS.
- C-3 ALL BAR REINFORCING SHALL CONFORM TO ASTM A615, GRADE 60 UNLESS NOTED OTHERWISE. WELDED WIRE FABRIC SHALL CONFORM TO ASTM A1064 .
- C-4 CONCRETE COVER FOR REINFORCING (UNLESS NOTED OTHERWISE ON THE DRAWINGS):  
  - A) CONCRETE DEPOSITED DIRECTLY AGAINST SOIL: 3"
  - B) CONCRETE EXPOSED TO WEATHER (#5 OR SMALLER): 1 1/2"
  - CONCRETE EXPOSED TO WEATHER (#6 OR LARGER): 2"
  - C) SLABS: 1 1/2"
  - AT SURFACES CONTACTING FLUID: 2"
  - D) BEAMS AND COLUMNS (TO MAIN REINFORCEMENT): 2"
  - BEAMS AND COLUMNS (TO COLUMN TIES OR STIRRUPS): 1 1/2"
  - E) WALLS 12" OR MORE: 2"
  - WALLS LESS THAN 12" (#5 OR SMALLER): 1 1/2"
  - WALLS LESS THAN 12" (#6 OR LARGER): 2"
  - F) FOR SURFACES EXPOSED TO FLUID IN BEAMS, COLUMNS AND WALLS: ADD 1/2" TO ABOVE VALUES
- C-5 SPLICES SHALL BE CLASS "B" CONFORMING TO THE PROVISIONS OF ACI 318 UNLESS NOTED OTHERWISE. SPLICE LENGTH FOR TWO DIFFERENT SIZED BARS TO BE LAP SPLICED TOGETHER SHALL BE THE LENGTH OF THE LARGER BAR UNLESS NOTED OTHERWISE.

**CONCRETE (CAST-IN-PLACE), CONTINUED**

- C-6 CONSTRUCTION JOINTS SHALL BE LOCATED AS SHOWN ON THE DRAWINGS. CONSTRUCTION JOINTS NOT SHOWN SHALL BE SUBMITTED BY THE CONTRACTOR FOR THE APPROVAL OF THE ENGINEER PRIOR TO SUBMITTING REBAR SHOP DRAWINGS.
- C-7 ALL JOINTS WHICH ARE IN MEMBERS IN CONTACT WITH LIQUID OR BELOW GRADE SHALL HAVE A WATERSTOP. CONSTRUCTION JOINTS SHALL HAVE A 6" PVC RIBBED WATERSTOP. EXPANSION JOINTS SHALL HAVE A 9" PVC CENTER BULB RIBBED WATERSTOP. IN VERTICAL JOINTS, WATERSTOPS SHALL TERMINATE NO LESS THAN 18" ABOVE THE MAXIMUM WATER SURFACE OR 18" ABOVE GRADE, WHICHEVER IS HIGHER.
- C-8 ALL EXPOSED CORNERS SHALL HAVE A 3/4" CHAMFER.
- C-9 EQUIPMENT SUPPORTS, ANCHORAGES, OPENINGS, RECESSES AND REVEALS NOT SHOWN ON THE STRUCTURAL DRAWINGS BUT REQUIRED BY OTHER CONTRACT DOCUMENTS, SHALL BE INSTALLED PRIOR TO PLACING CONCRETE.
- C-10 REINFORCING BARS AND ACCESSORIES SHALL NOT BE IN CONTACT WITH ANY METAL PIPE, PIPE FLANGE, METAL CONDUIT, OR OTHER METAL PARTS EMBEDDED IN CONCRETE. A MINIMUM CLEARANCE OF 2" SHALL BE PROVIDED.
- C-11 CONDUITS AND OTHER SIMILAR ITEMS EMBEDDED IN OR PENETRATING THROUGH CONCRETE SHALL BE SPACED ON CENTER NOT LESS THAN 3 TIMES THEIR OUTSIDE DIMENSION, BUT NOT LESS THAN 2 1/2" CLEAR. WHEN SUCH ITEMS ARE EMBEDDED IN WALLS OR SLABS, THEY SHALL NOT OCCUPY MORE THAN 1/3 OF THE MEMBER THICKNESS.
- C-12 AT ALL TYPICAL CURBS, EQUIPMENT PADS, AND PIPE SUPPORT PIERS, REINFORCING DOWELS SHOWN MAY BE REPLACED WITH MATCHING DOWELS SET IN EPOXY IN DRILLED HOLES AS SPECIFIED. DOWELS LOCATED CLOSER THAN 3" FROM ANY EDGE OF CONCRETE SHALL NOT BE REPLACED WITH DRILLED DOWELS.
- C-13 ADJUST THE LOCATION OF DOWELS OR ANCHORS PLACED INTO HARDENED CONCRETE AS NEEDED TO AVOID DRILLING THROUGH ANY REINFORCING BARS. IF THE LOCATION NEEDS TO BE MODIFIED, CONTACT THE ENGINEER. CONTRACTOR SHALL USE NON-DESTRUCTIVE MEANS TO FIELD LOCATE REINFORCEMENT PRIOR TO DRILLING HOLES FOR DOWELS OR ANCHORS.
- C-14 CLEAR DISTANCE FROM ANCHOR RODS TO ANY CONCRETE EDGE SHALL BE 4" MINIMUM UNLESS NOTED OTHERWISE.

**DEMOLITION**

- D-1 FOR DEMOLITION REQUIREMENTS, REFER TO SPECIFICATION 01 73 00 - EXECUTION OF WORK.
- D-2 CONCRETE DEMOLITION WITHIN STRUCTURES BEING MODIFIED SHALL BE SELECTIVE DEMOLITION BY CORE DRILLING OR SAWCUTTING AND CAREFUL REMOVAL OF CONCRETE SHOWN TO BE REMOVED. NO OVER CUTTING OF AREAS TO BE DEMOLISHED SHALL BE PERMITTED. CONTRACTOR SHALL CORE DRILL CORNERS OF OPENING PRIOR TO SAWCUTTING. EXPLOSIVES AND VIBRATORY HAMMERS SHALL NOT BE USED FOR DEMOLITION WORK.
- D-3 UNLESS ANCHORING DEVICES AND/OR REINFORCEMENT IS NOTED TO REMAIN FOLLOWING DEMOLITION, REMOVE AND/OR BURN BACK ANCHORS AND REINFORCEMENT STEEL 1/2" MIN BELOW SURFACE AND VOIDS CREATED SHALL BE FILLED WITH EPOXY RESIN BINDER.
- D-4 EMBEDDED CONDUIT ENCOUNTERED DURING DEMOLITION WORK LIMITS SHALL BE PERMANENTLY REROUTED AS NECESSARY. CONTRACTOR SHALL SUBMIT PROPOSED MEANS OF REROUTING ANY INTERFERING CONDUIT.
- D-5 WHERE DRAWINGS INDICATE A CONCRETE EQUIPMENT PAD TO BE DEMOLISHED, THE FLOOR SLAB SURFACE SHALL BE REPAIRED AS APPROVED BY ENGINEER. FOLLOWING SELECT DEMOLITION AND REMOVAL OF THE EQUIPMENT PAD REMOVAL THE REPAIR SHALL BE:  
  - A. SAWCUT THE FLOOR AROUND THE EQUIPMENT PAD PERIMETER TO A DEPTH OF 1/4"
  - B. SCARIFY AND REMOVE SLAB CONCRETE WITHIN THE PERIMETER TO A NOMINAL 1/4" DEPTH CLEAN AND REMOVE ALL CONCRETE LAITANCE.
  - C. RESURFACE THE AREA BY APPLYING A POLYMER MODIFIED OR SILICA FUME ENHANCED CEMENTITIOUS REPAIR MORTAR, APPROVED BY THE ENGINEER, FOLLOWING THE MANUFACTURER'S SURFACE PREPARATION AND APPLICATION RECOMMENDATIONS. LEVEL AND FINISH THE SURFACE TO MATCH THE FLOOR SLAB SURROUNDING AREA.
- D-6 PRIOR TO DEMOLITION OF SMALL OPENINGS (LESS THAN 6 INCHES IN SIZE) FOR PENETRATIONS, ETC., CONTRACTOR SHALL USE NON-DESTRUCTIVE MEANS TO FIELD LOCATE REINFORCEMENT. OPENINGS SHALL BE LOCATED TO AVOID CUTTING THROUGH EXISTING REINFORCEMENT, IF POSSIBLE. EXISTING REINFORCEMENT SHALL NOT BE CUT WITHOUT APPROVAL OF ENGINEER.
- D-7 CONCRETE SURFACES LEFT EXPOSED FOLLOWING DEMOLITION SHALL BE SEALED WITH EPOXY RESIN COATING SUCH AS DURALKOTE 240 BY EUCLID CHEMICAL, OR APPROVED EQUAL.
- D-8 DETAILED CONSTRUCTION AND DEMOLITION PLAN SHALL BE SUBMITTED TO THE ENGINEER AND APPROVED BY THE ENGINEER AND OWNER PRIOR TO BEGINNING CONSTRUCTION. ANY SHUTDOWNS SHALL BE SUBMITTED TO, COORDINATED WITH, AND APPROVED BY THE OWNER. ONCE APPROVED, CONTRACTOR SHALL PROVIDE A MINIMUM OF THREE (3) WEEKS NOTICE TO OWNER PRIOR TO SHUTDOWN.

**EXISTING INFORMATION**

- X-1 ALL EXISTING INFORMATION SHOWN ON THESE DRAWINGS INCLUDING LOCATION, DIMENSIONS, ELEVATIONS, AND CONFIGURATIONS IS DERIVED FROM THE AUGUST 1991 CONTRACT DRAWINGS AND IS NOT GUARANTEED TO BE COMPLETE OR CORRECT.
- X-2 THE CONTRACTOR IS RESPONSIBLE FOR VERIFYING ALL EXISTING INFORMATION IN THE FIELD AS REQUIRED FOR DEMOLITION AND MODIFICATIONS.

**SPECIAL INSPECTIONS**

- SI-1 SPECIAL INSPECTIONS SHALL BE IN ACCORDANCE WITH SPECIFICATIONS AND THE 2018 INTERNATIONAL BUILDING CODE.

**DELEGATED STRUCTURAL DESIGN ITEMS**

- DSD-1 THE FOLLOWING ITEMS SHALL BE SUBMITTED AS DELEGATED STRUCTURAL DESIGNS DURING CONSTRUCTION, IN ACCORDANCE WITH THE CONTRACT DRAWINGS AND SPECIFICATIONS.  
  - A. POLYMER PRECAST CONCRETE MANHOLES
- DSD-2 DRAWINGS AND CALCULATIONS FOR EACH ITEM SHALL BE SIGNED AND SEALED BY A PROFESSIONAL ENGINEER REGISTERED IN THE STATE OF TEXAS.

**ABBREVIATIONS**

EF	EACH FACE
EW	EACH WAY
EXIST/EX	EXISTING
CONC	CONCRETE
CONN	CONNECTION
CONST	CONSTRUCTION
DWLS	DOWELS
JT	JOINT
MH	MANHOLE
OPNG	OPENING
PVC	POLYVINYL CHLORIDE
RCP	REINFORCED CONCRETE PIPE
REINF	REINFORCEMENT
SECT	SECTION
T&B	TOP AND BOTTOM
TYP	TYPICAL
W/	WITH
WS	WATERSTOP

C:\Users\B\onenza\Documents\6006-000-HRS\MRS-S\_Nierenza\CBF\05.rvt 4/18/2025 12:53:12 PM

				PROJECT ENGINEER: J. FORD
				DESIGNED BY: J. FORD
				DRAWN BY: B. LORENZEN
				CHECKED BY: F. POWELL
				IF THIS BAR DOES NOT MEASURE 1" THEN DRAWING IS NOT TO FULL SCALE
				0 1/2" 1"
REV	ISSUED FOR	DATE	BY	

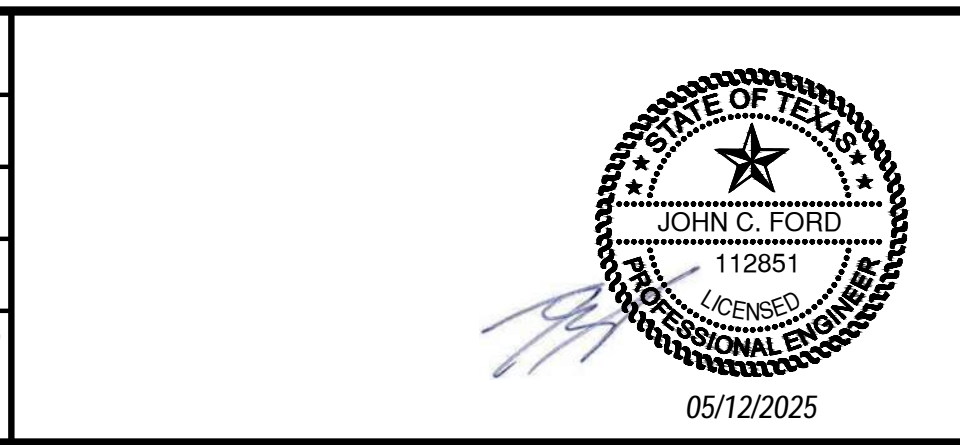

**Hazen**  
 HAZEN AND SAWYER  
 8150 NORTH CENTRAL EXPRESSWAY  
 TOWER II SUITE 700  
 DALLAS, TEXAS 75206  
 TBPELS Reg. No. F-13618

**MESQUITE**  
 T E X A S  
 Real. Texas. Flavor.

CITY OF MESQUITE  
 TEXAS

SAMUELL PARKS FARMS/SCYENE  
 SEWER MAIN REPAIR/REHABILITATION

STRUCTURAL  
 GENERAL NOTES

DATE:	APRIL 2025
HAZEN NO.:	60006-000
CONTRACT NO.:	2025-073
DRAWING NUMBER:	S001

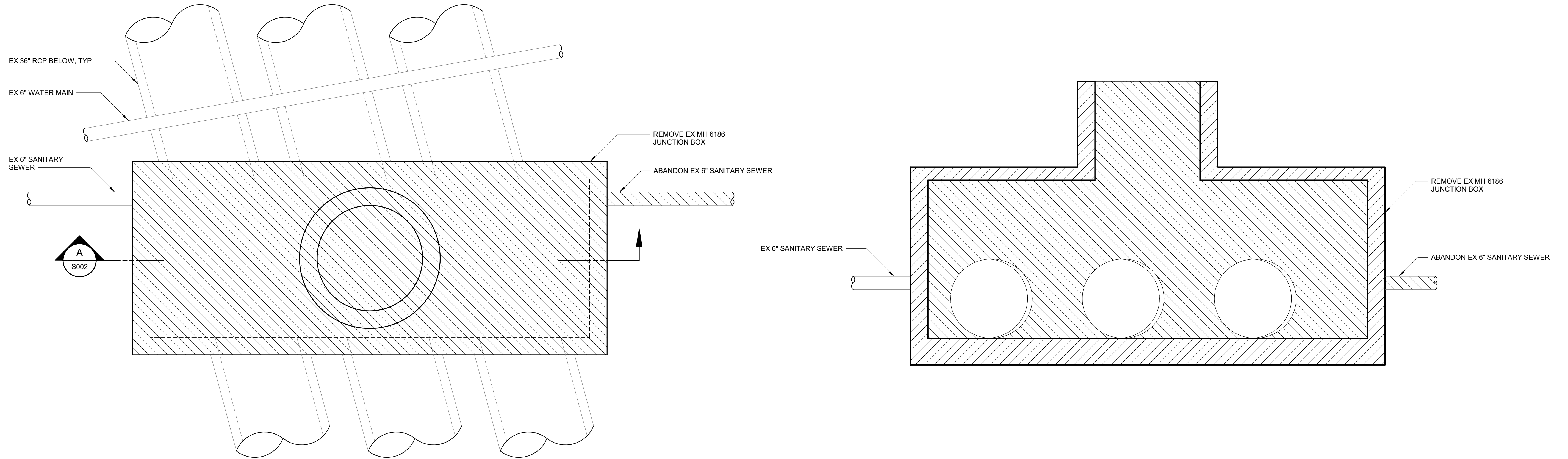
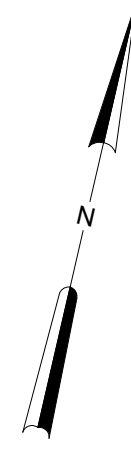

**MH 6186 DEMOLITION PLAN**  
1/2" = 1'-0"

**SECTION A**  
1/2" = 1'-0"

C:\Users\B.Lorenzen\Documents\6006-000-HRS\MRS-S\_Niemzen\CB\F5.rvt 4/18/2025 12:53:12 PM

REV	ISSUED FOR	DATE	BY

PROJECT ENGINEER:	J. FORD
DESIGNED BY:	J. FORD
DRAWN BY:	B. LORENZEN
CHECKED BY:	F. POWELL
IF THIS BAR DOES NOT MEASURE 1" THEN DRAWING IS NOT TO FULL SCALE	

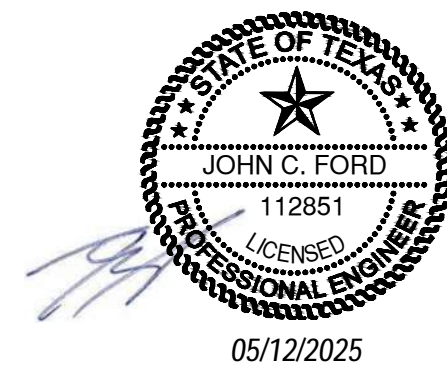

**Hazen**  
HAZEN AND SAWYER  
8150 NORTH CENTRAL EXPRESSWAY  
TOWER II SUITE 700  
DALLAS, TEXAS 75206  
TBPELS Reg. No. F-13618



CITY OF MESQUITE  
TEXAS

SAMUELL PARKS FARMS/SCYENE  
SEWER MAIN REPAIR/REHABILITATION

STRUCTURAL  
JUNCTION BOX SM 6186 DEMOLITION PLAN AND  
SECTION

DATE:	APRIL 2025
HAZEN NO.:	60006-000
CONTRACT NO.:	2025-073
DRAWING NUMBER:	S002

**NOTES:**

1. APPLY MIC COATING TO ALL INTERIOR CAST-IN-PLACE CONCRETE SURFACES PER SPECIFICATION 09 96 59.
2. CONCRETE FILL SHALL BE SIKACRETE 211 PLUS BY SIKA CORP.
3. CONTRACTOR SHALL BE SOLELY RESPONSIBLE FOR THE TEMPORARY SUPPORT OF THE EXISTING PIPES THROUGHOUT THE DURATION OF CONSTRUCTION. CONTRACTOR SHALL SUBMIT CALCULATIONS AND ERECTION DRAWINGS OF THE SUPPORT METHOD TO MAINTAIN THE STRUCTURAL INTEGRITY OF THE PIPE AND THE SURROUNDING EXCAVATION SYSTEM. CALCULATIONS AND DRAWINGS SHALL BE SIGNED AND SEALED BY A PROFESSIONAL ENGINEER CURRENTLY REGISTERED IN THE STATE OF TEXAS.
4. THE EXISTING RCP PIPES SHALL NOT BE DAMAGED DURING DEMOLITION AND CONSTRUCTION OF THE JUNCTION STRUCTURES. THE CONTRACTOR SHALL BE FULLY RESPONSIBLE FOR REMOVAL AND REPLACEMENT OF SECTIONS OF THE EXISTING RCP PIPES AS REQUIRED FOR CONSTRUCTION. LIMITS OF DEMOLITION ARE NOT SHOWN AND ARE TO BE ESTABLISHED BY THE CONTRACTOR. CONTRACTOR TO SUBMIT DEMOLITION PLAN TO THE ENGINEER FOR REVIEW.
5. CONTRACTOR SHALL VERIFY ALL EXISTING DIMENSIONS AND ELEVATIONS.
6. INVERT OF JUNCTION BOX TO BE SHAPED WITH CONCRETE FILL TO EFFECT DRAINAGE TO OUTLET PIPES.

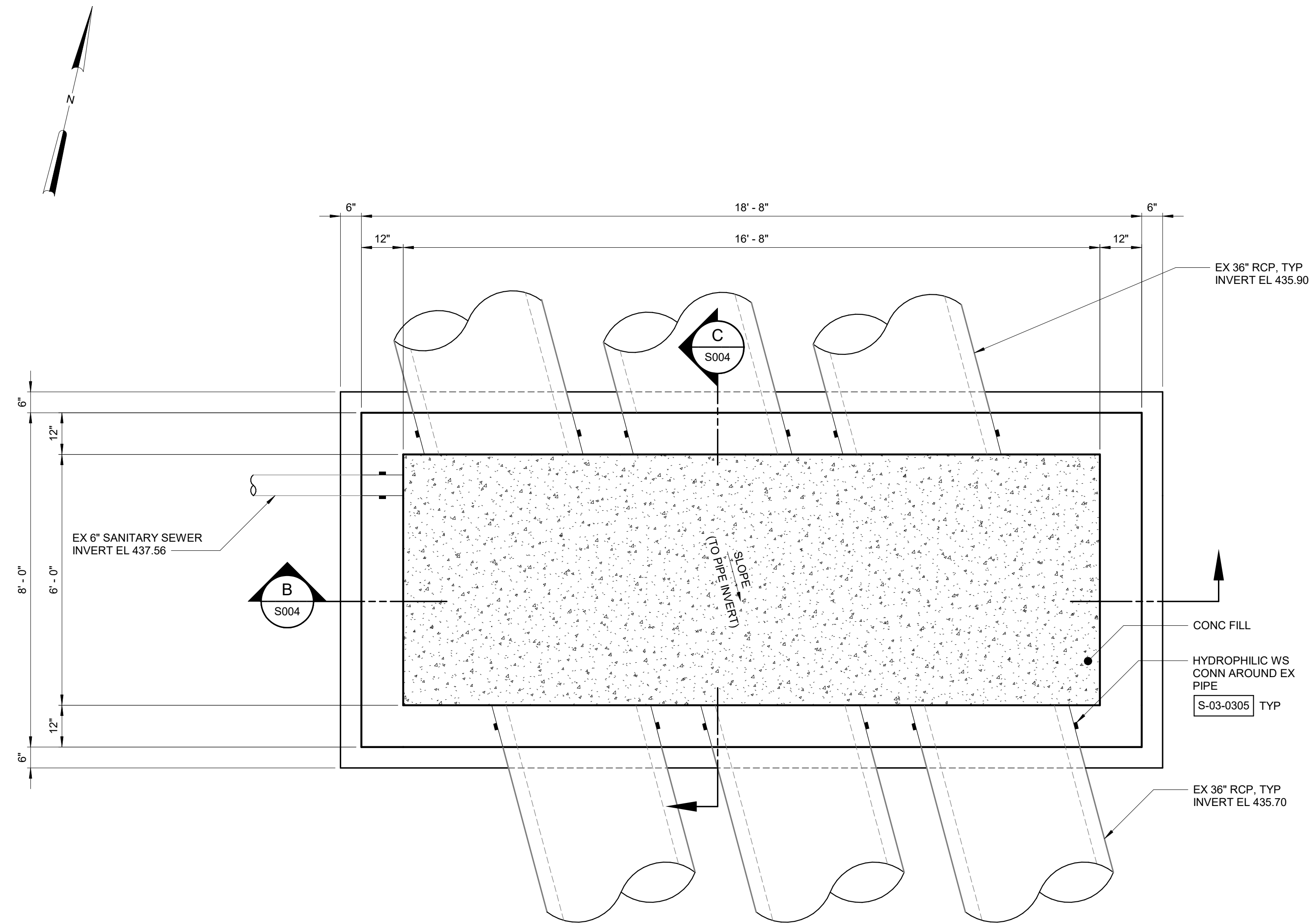

**MH 6186 BOTTOM PLAN**  
1/2" = 1'-0"

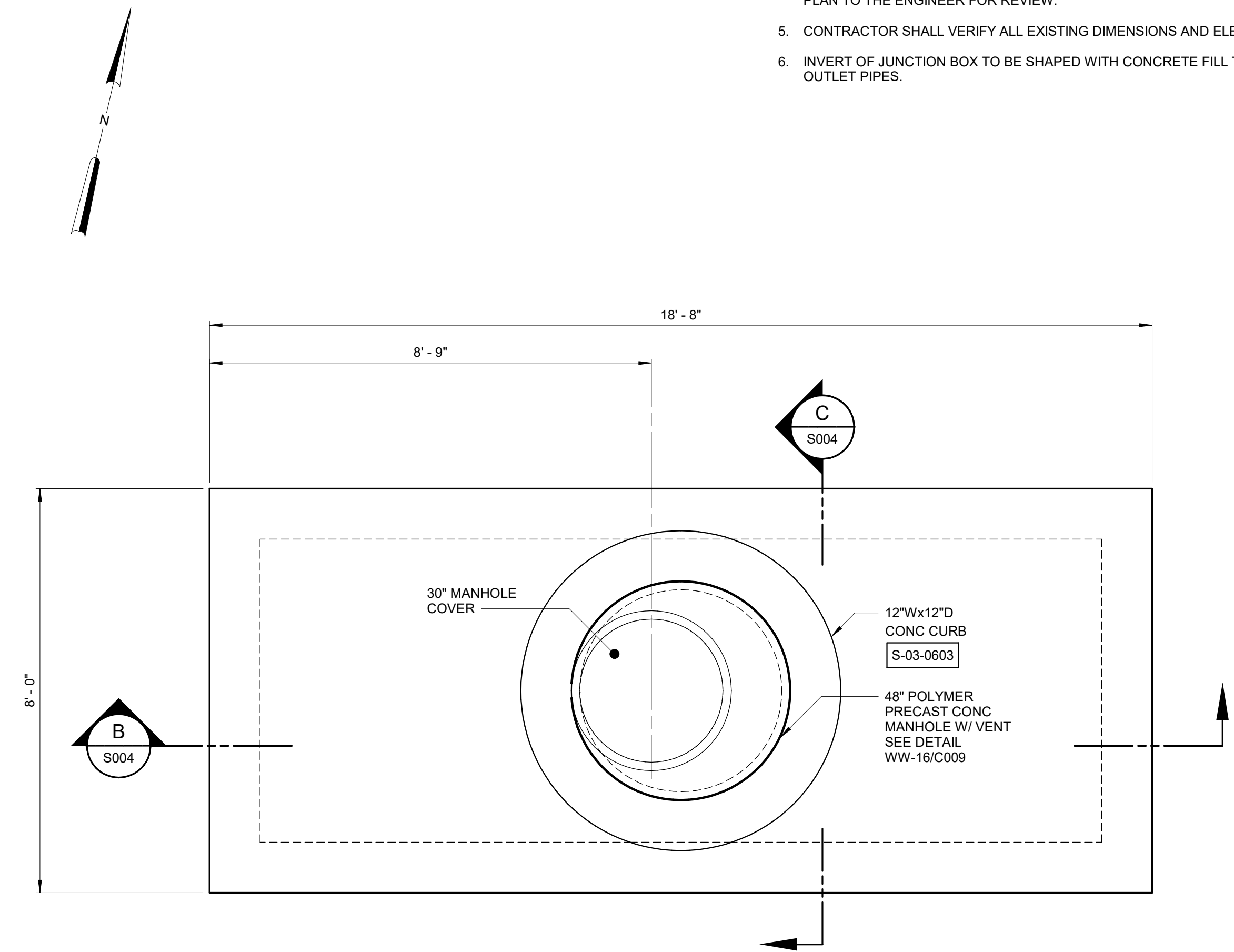

**MH 6186 TOP PLAN**  
1/2" = 1'-0"

C:\Users\blorenzen\Documents\6006-C00-HRS\MRS-S\_Nierenzen\CBF\5.rvt 4/18/2025 12:53:12 PM

REV	ISSUED FOR	DATE	BY

PROJECT ENGINEER:	J. FORD
DESIGNED BY:	J. FORD
DRAWN BY:	B. LORENZEN
CHECKED BY:	F. POWELL
IF THIS BAR DOES NOT MEASURE 1" THEN DRAWING IS NOT TO FULL SCALE	

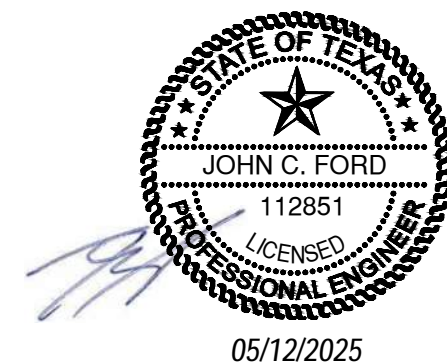

**Hazen**  
HAZEN AND SAWYER  
8150 NORTH CENTRAL EXPRESSWAY  
TOWER II SUITE 700  
DALLAS, TEXAS 75206  
TBPELS Reg. No. F-13618



CITY OF MESQUITE  
TEXAS

SAMUELL PARKS FARMS/SCYENE  
SEWER MAIN REPAIR/REHABILITATION

STRUCTURAL  
JUNCTION BOX SM 6186 PLANS

DATE:	APRIL 2025
HAZEN NO.:	60006-000
CONTRACT NO.:	2025-073
DRAWING NUMBER:	S003

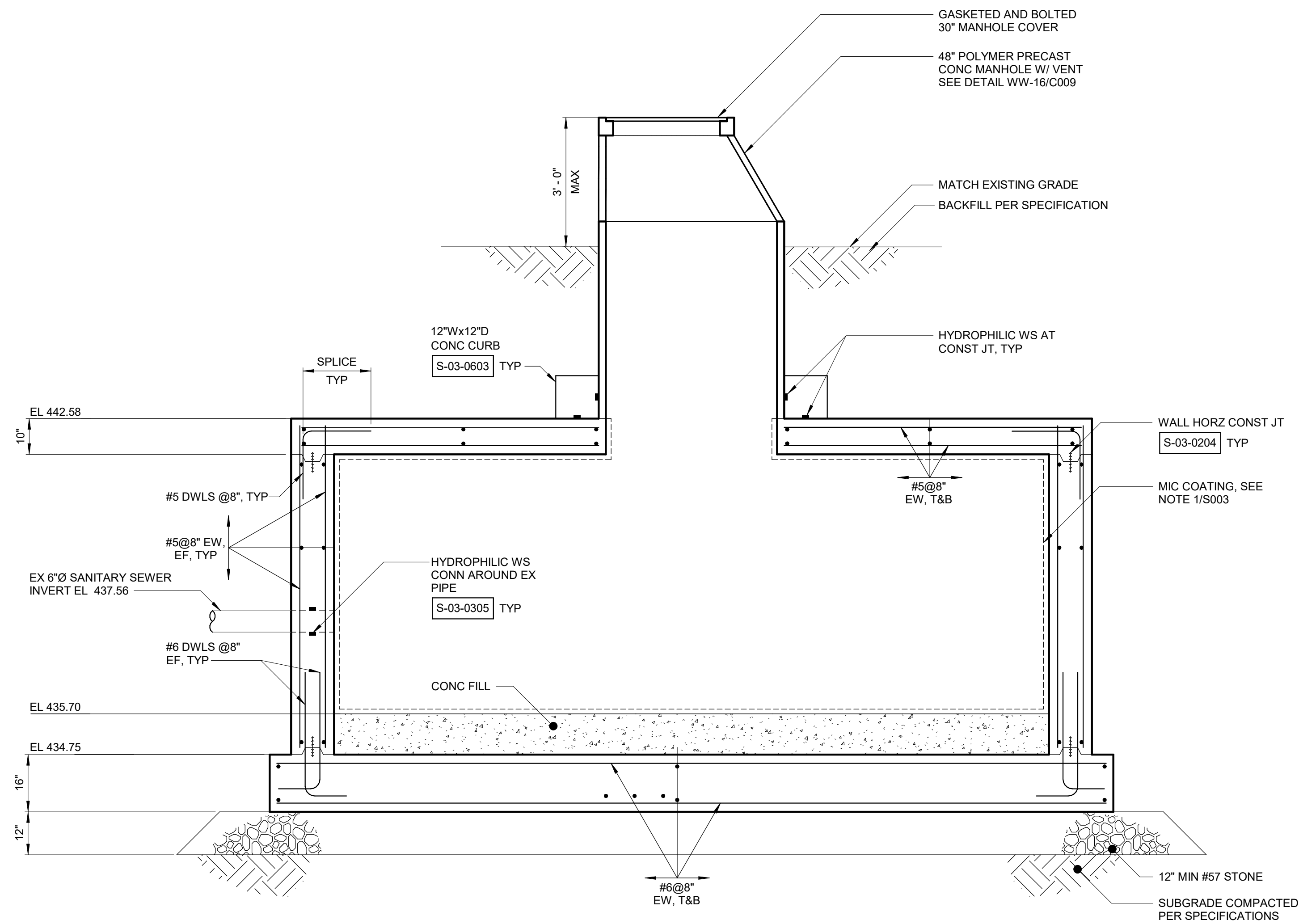

SECTION B  
1/2" = 1'-0" S003

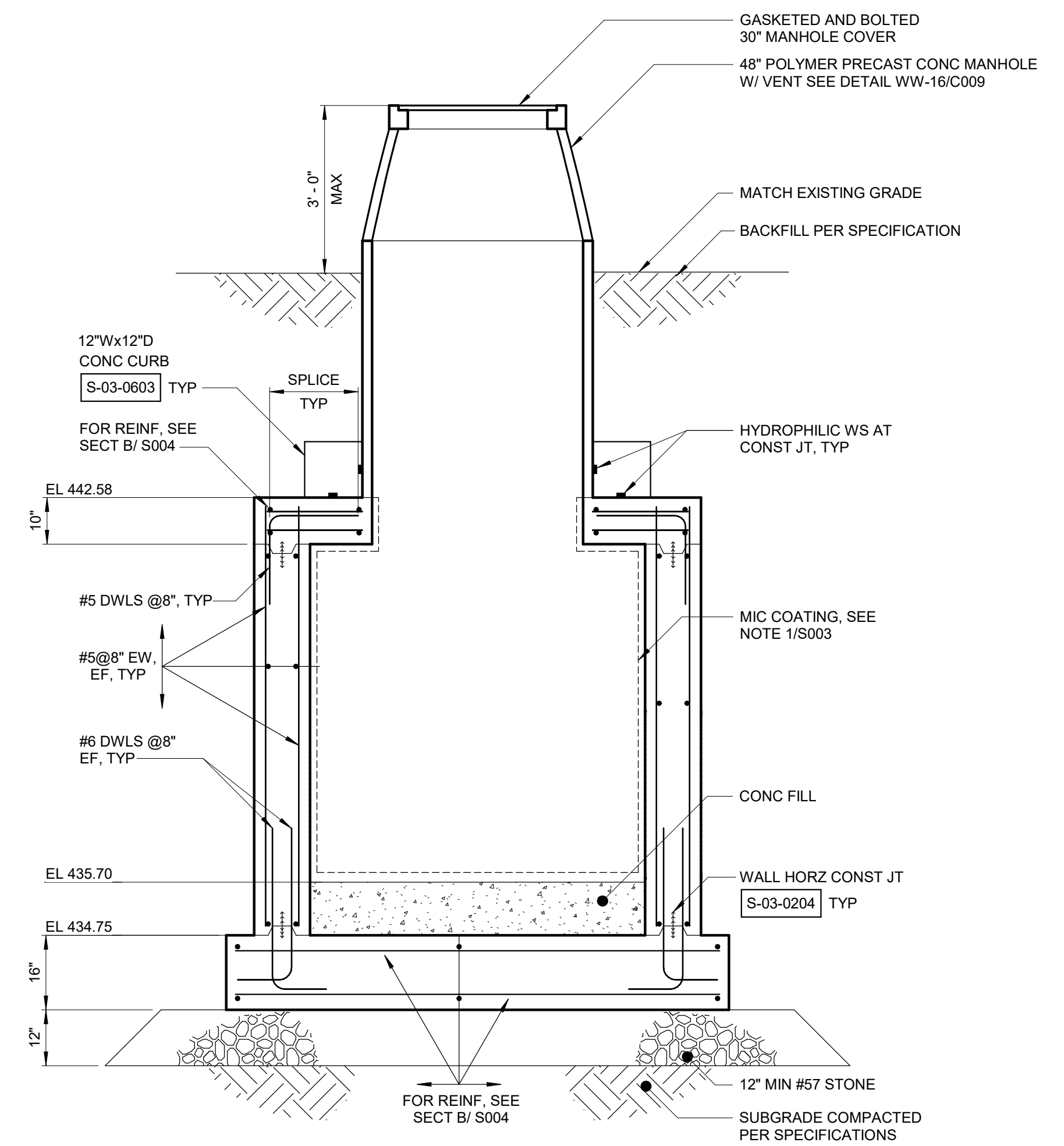

SECTION C  
1/2" = 1'-0" S003

C:\Users\blorrenz\OneDrive\Documents\6006-000-HRS\MRS-S\_Nierenstein\CB\F15.rvt  
4/18/2025 12:53:12 PM

REV	ISSUED FOR	DATE	BY

PROJECT ENGINEER:	J. FORD
DESIGNED BY:	J. FORD
DRAWN BY:	B. LORENZEN
CHECKED BY:	F. POWELL
IF THIS BAR DOES NOT MEASURE 1" THEN DRAWING IS NOT TO FULL SCALE	0 1/2" 1"

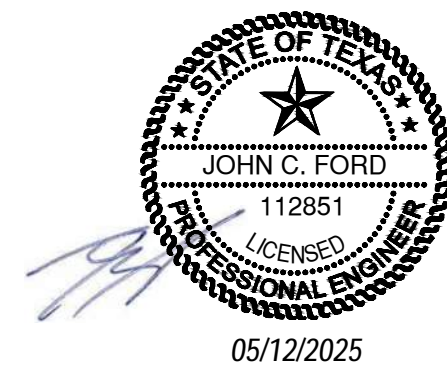

**Hazen**  
HAZEN AND SAWYER  
8150 NORTH CENTRAL EXPRESSWAY  
TOWER II SUITE 700  
DALLAS, TEXAS 75206  
TBPELS Reg. No. F-13618



CITY OF MESQUITE  
TEXAS

SAMUELL PARKS FARMS/SCYENE  
SEWER MAIN REPAIR/REHABILITATION

STRUCTURAL  
JUNCTION BOX SM 6186 SECTIONS

DATE:	APRIL 2025
HAZEN NO.:	60006-000
CONTRACT NO.:	2025-073
DRAWING NUMBER:	S004

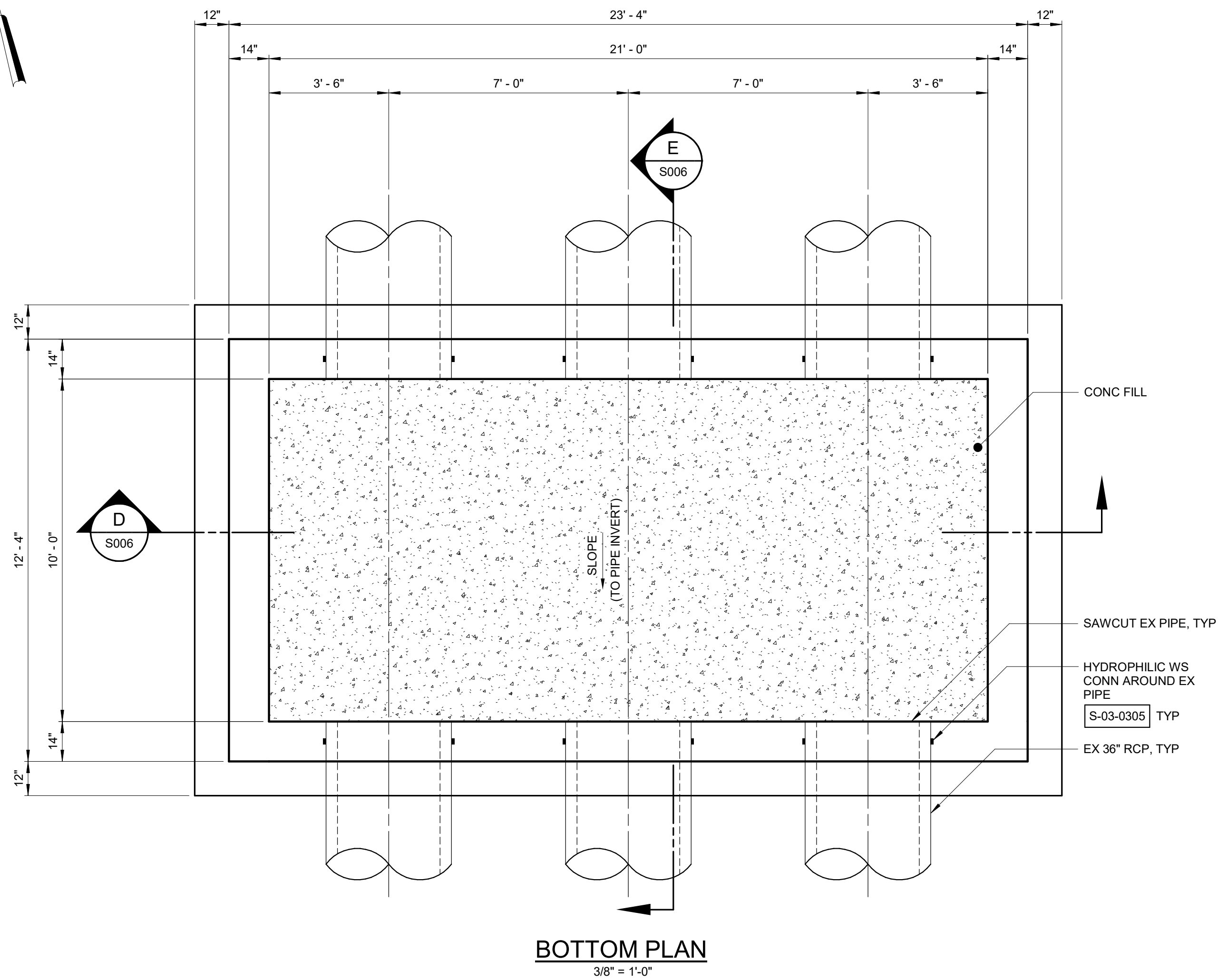

**BOTTOM PLAN**  
3/8" = 1'-0"

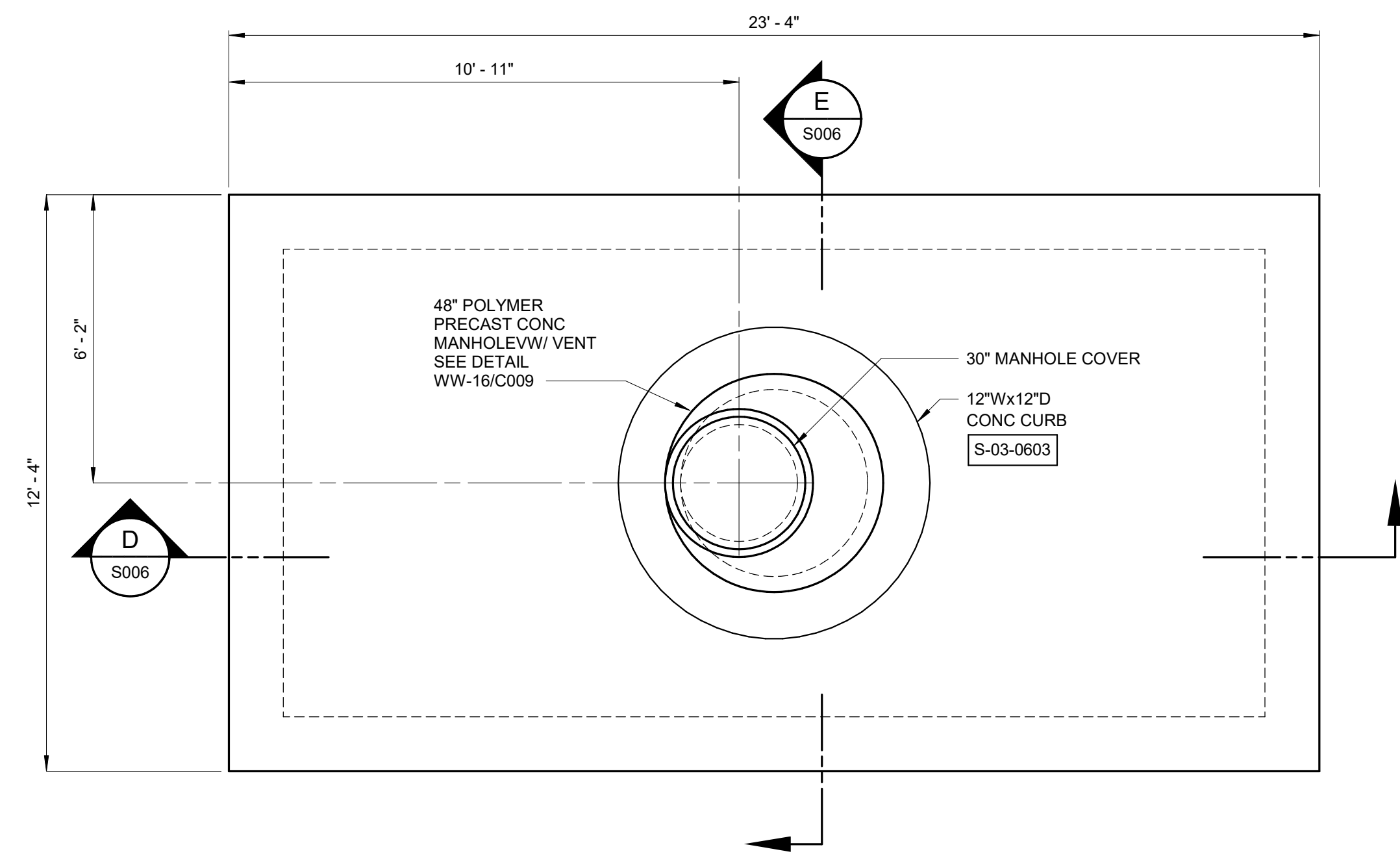

**TOP PLAN**  
3/8" = 1'-0"

C:\Users\B.Lorenzen\Documents\6006-000-HRS\MRS-S\_Niemzen\CBF\5.rvt 4/18/2025 12:53:12 PM

REV	ISSUED FOR	DATE	BY

PROJECT ENGINEER:	J. FORD
DESIGNED BY:	J. FORD
DRAWN BY:	B. LORENZEN
CHECKED BY:	F. POWELL
IF THIS BAR DOES NOT MEASURE 1" THEN DRAWING IS NOT TO FULL SCALE	

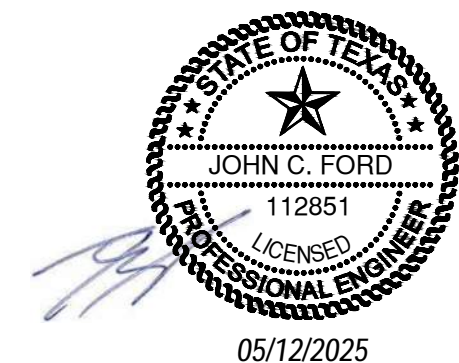

**Hazen**  
HAZEN AND SAWYER  
8150 NORTH CENTRAL EXPRESSWAY  
TOWER II SUITE 700  
DALLAS, TEXAS 75206  
TBPELS Reg. No. F-13618



CITY OF MESQUITE  
TEXAS

SAMUELL PARKS FARMS/SCYENE  
SEWER MAIN REPAIR/REHABILITATION

STRUCTURAL  
PROPOSED JUNCTION BOX PLANS

DATE:	APRIL 2025
HAZEN NO.:	60006-000
CONTRACT NO.:	2025-073
DRAWING NUMBER:	S005

**NOTES:**

1. APPLY MIC COATING TO ALL INTERIOR CAST-IN-PLACE CONCRETE SURFACES PER SPECIFICATION 09 96 59.
2. CONCRETE FILL SHALL BE SIKACRETE 211 PLUS BY SIKA CORP.
3. CONTRACTOR SHALL BE SOLELY RESPONSIBLE FOR THE TEMPORARY SUPPORT OF THE EXISTING 36" RCP PIPES THROUGHOUT THE DURATION OF CONSTRUCTION. CONTRACTOR SHALL SUBMIT CALCULATIONS AND ERECTION DRAWINGS OF THE SUPPORT METHOD TO MAINTAIN THE STRUCTURAL INTEGRITY OF THE PIPE AND THE SURROUNDING EXCAVATION SYSTEM. CALCULATIONS AND DRAWINGS SHALL BE SIGNED AND SEALED BY A PROFESSIONAL ENGINEER CURRENTLY REGISTERED IN THE STATE OF TEXAS.
4. THE EXISTING RCP PIPES SHALL NOT BE DAMAGED DURING DEMOLITION AND CONSTRUCTION OF THE JUNCTION STRUCTURES. THE CONTRACTOR SHALL BE FULLY RESPONSIBLE FOR REMOVAL AND REPLACEMENT OF SECTIONS OF THE EXISTING RCP PIPES AS REQUIRED FOR CONSTRUCTION. LIMITS OF DEMOLITION ARE NOT SHOWN AND ARE TO BE ESTABLISHED BY THE CONTRACTOR. CONTRACTOR TO SUBMIT DEMOLITION PLAN TO THE ENGINEER FOR REVIEW.
5. CONTRACTOR SHALL VERIFY ALL EXISTING DIMENSIONS AND ELEVATIONS.
6. INVERT OF JUNCTION BOX TO BE SHAPED WITH CONCRETE FILL TO EFFECT DRAINAGE TO OUTLET PIPES.

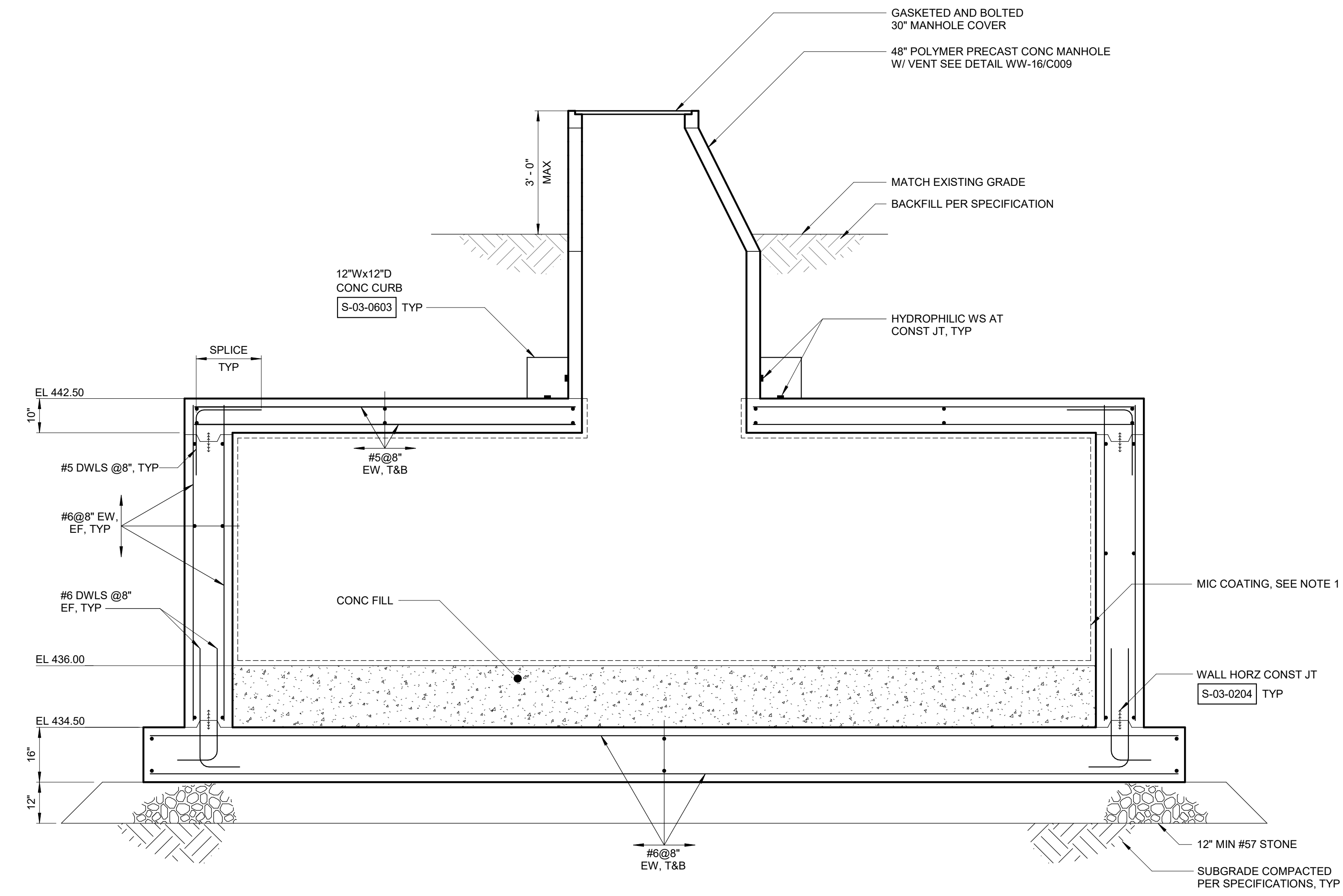

**SECTION D**  
1/2" = 1'-0"  
S005

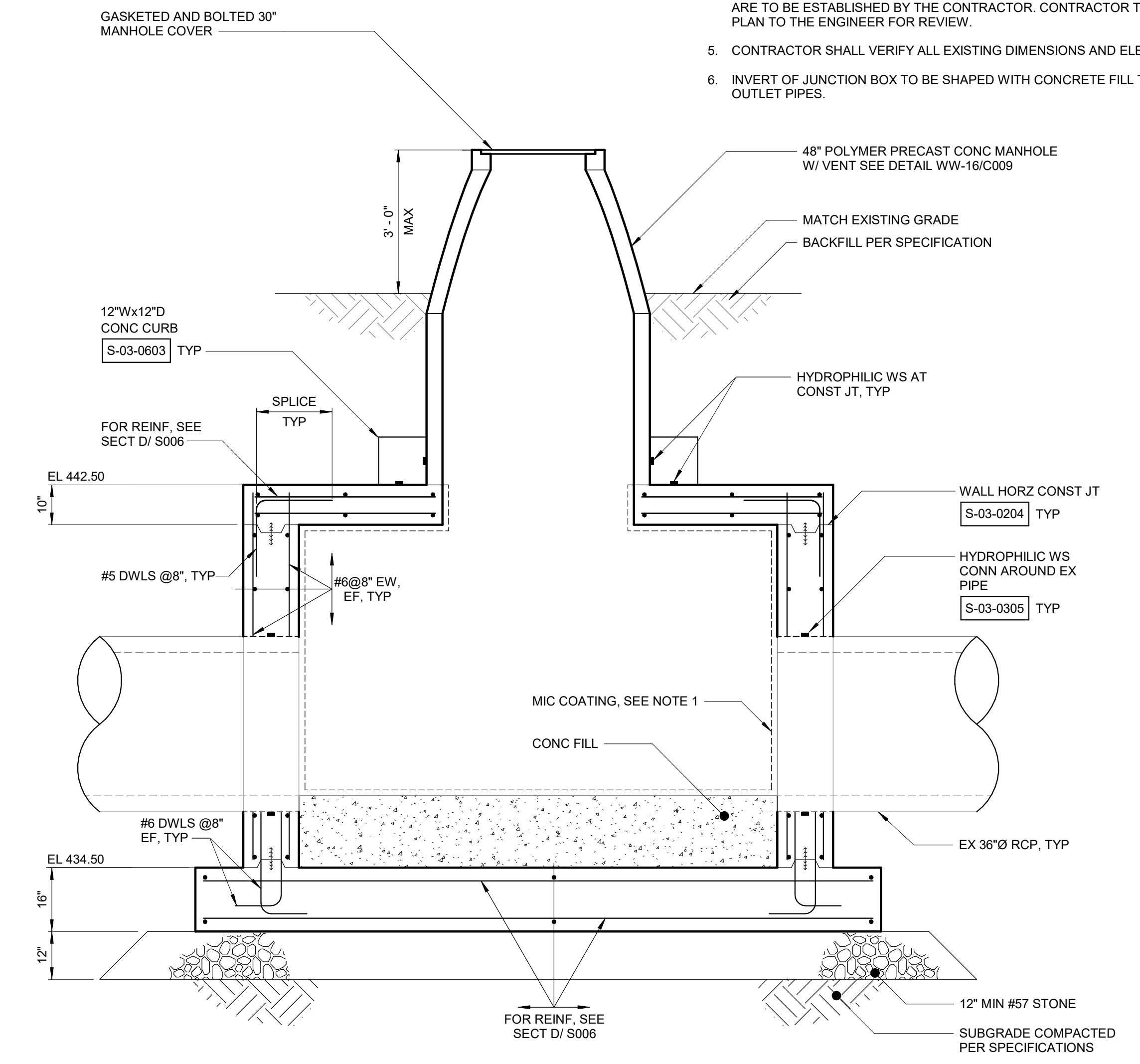

**SECTION E**  
1/2" = 1'-0"  
S005

C:\Users\blorenzen\Documents\6006-000-HRS\MRS-S\_Nierenstein\CB\F15.rvt 4/18/2025 12:53:12 PM

PROJECT ENGINEER:	J. FORD		
DESIGNED BY:	J. FORD		
DRAWN BY:	B. LORENZEN		
CHECKED BY:	F. POWELL		
IF THIS BAR DOES NOT MEASURE 1" THEN DRAWING IS NOT TO FULL SCALE	0 1/2" 1"		
REV	ISSUED FOR	DATE	BY

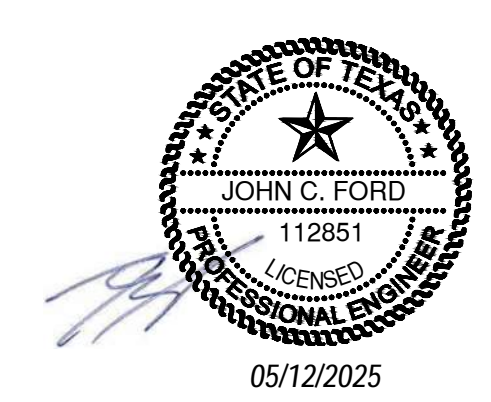

**Hazen**  
HAZEN AND SAWYER  
8150 NORTH CENTRAL EXPRESSWAY  
TOWER II SUITE 700  
DALLAS, TEXAS 75206  
TBPELS Reg. No. F-13618

**MESQUITE**  
T E X A S  
Real. Texas. Flavor.

CITY OF MESQUITE  
TEXAS

SAMUELL PARKS FARMS/SCYENE  
SEWER MAIN REPAIR/REHABILITATION

STRUCTURAL  
PROPOSED JUNCTION BOX SECTIONS

DATE:	APRIL 2025
HAZEN NO.:	60006-000
CONTRACT NO.:	2025-073
DRAWING NUMBER:	S006

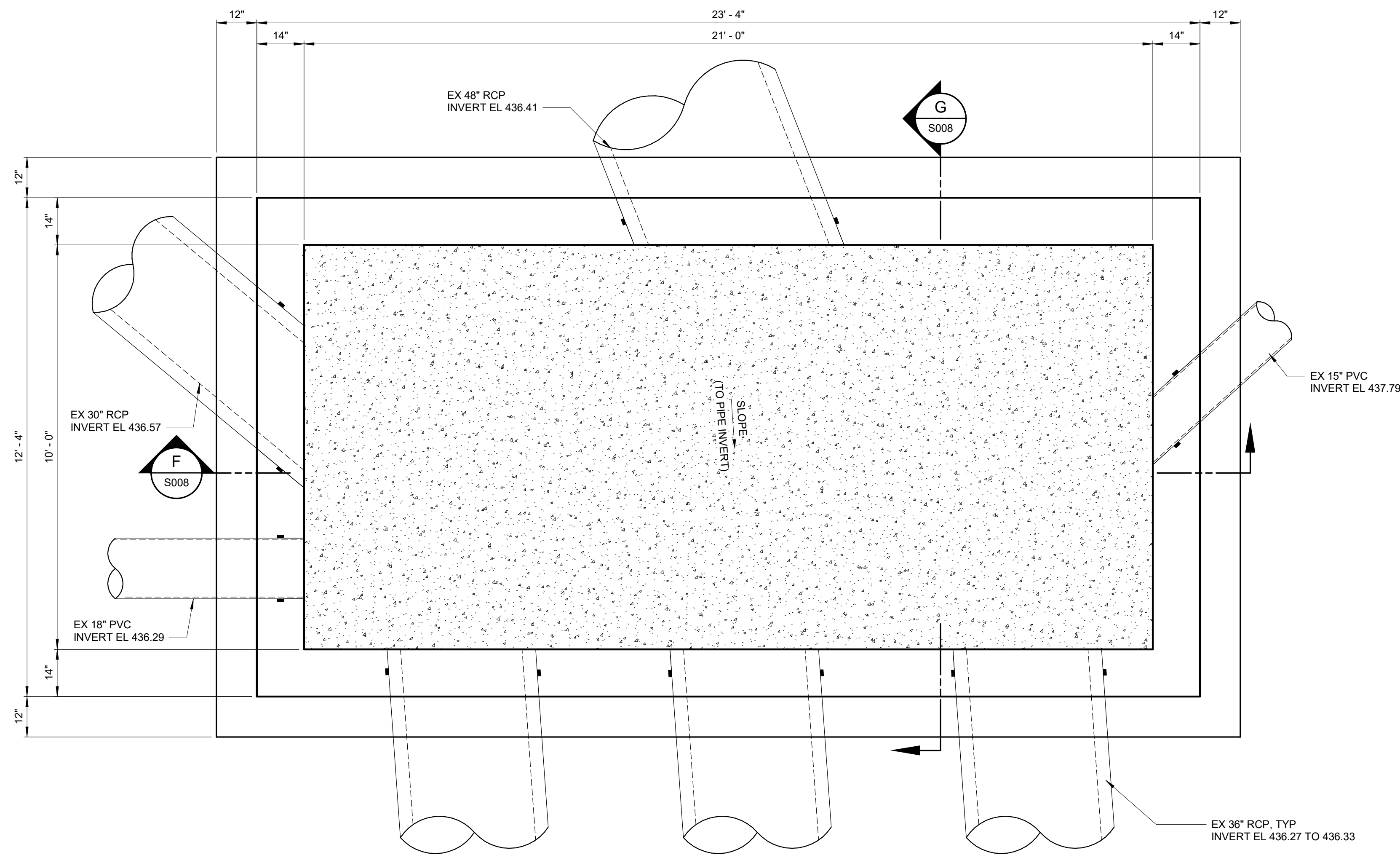

**SM 6183 BOTTOM PLAN**

1/2" = 1'-0"

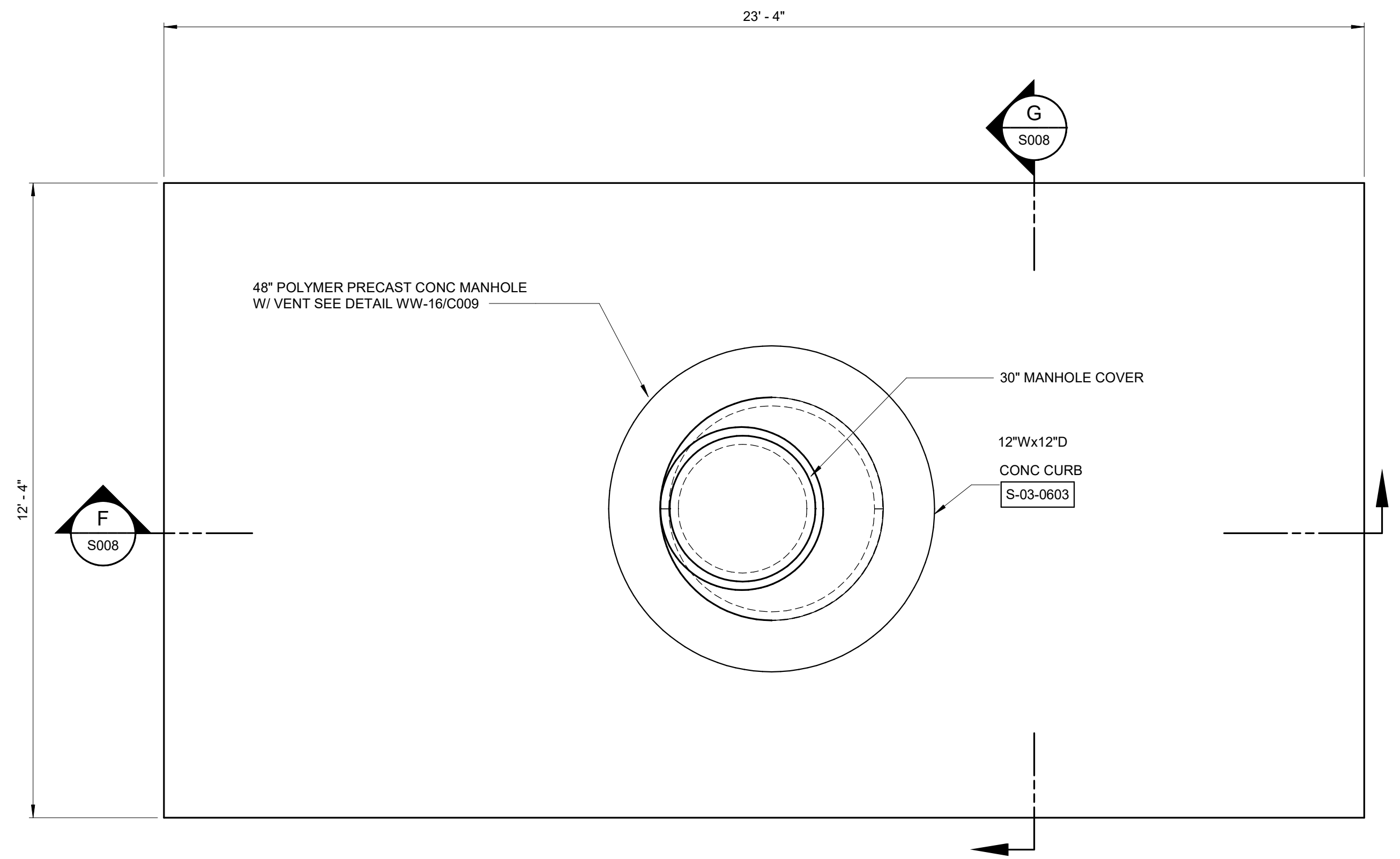

**SM 6183 TOP PLAN**

1/2" = 1'-0"

C:\Users\bl... \Documents\6006-000-HRS\MRS-S\_Nierman\CB\F5.rvt 4/18/2025 12:53:12 PM

REV	ISSUED FOR	DATE	BY

PROJECT ENGINEER:	J. FORD
DESIGNED BY:	J. FORD
DRAWN BY:	T. JOUDEH
CHECKED BY:	F. POWELL
IF THIS BAR DOES NOT MEASURE 1" THEN DRAWING IS NOT TO FULL SCALE	

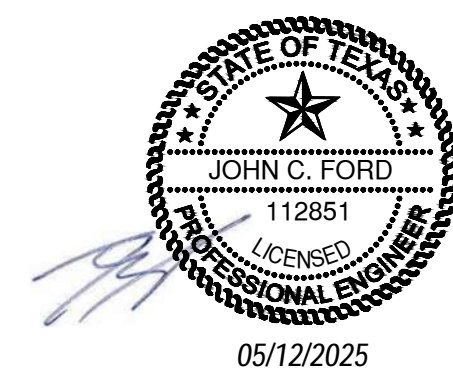

**Hazen**  
 HAZEN AND SAWYER  
 8150 NORTH CENTRAL EXPRESSWAY  
 TOWER II SUITE 700  
 DALLAS, TEXAS 75206  
 TBPELS Reg. No. F-13618



CITY OF MESQUITE  
 TEXAS

SAMUEL PARKS FARMS/SCYENE  
 SEWER MAIN REPAIR/REHABILITATION

STRUCTURAL  
 JUNCTION BOX SM 6183 PLANS

DATE:	APRIL 2025
HAZEN NO.:	60006-000
CONTRACT NO.:	2025-073
DRAWING NUMBER:	S007

**NOTES:**

1. APPLY MIC COATING TO ALL INTERIOR CAST-IN-PLACE CONCRETE SURFACES PER SPECIFICATION 09 96 59.
2. CONCRETE FILL SHALL BE SIKACRETE 211 PLUS BY SIKA CORP.
3. CONTRACTOR SHALL BE SOLELY RESPONSIBLE FOR THE TEMPORARY SUPPORT OF THE EXISTING PIPES AND MANHOLES THROUGHOUT THE DURATION OF CONSTRUCTION. CONTRACTOR SHALL SUBMIT CALCULATIONS AND ERECTION DRAWINGS OF THE SUPPORT METHOD TO MAINTAIN THE STRUCTURAL INTEGRITY OF THE PIPE AND MANHOLES AND THE SURROUNDING EXCAVATION SYSTEM. CALCULATIONS AND DRAWINGS SHALL BE SIGNED AND SEALED BY A PROFESSIONAL ENGINEER CURRENTLY REGISTERED IN THE STATE OF TEXAS.
4. THE EXISTING PIPES SHALL NOT BE DAMAGED DURING DEMOLITION AND CONSTRUCTION OF THE JUNCTION STRUCTURES. THE CONTRACTOR SHALL BE FULLY RESPONSIBLE FOR REMOVAL AND REPLACEMENT OF SECTIONS OF THE EXISTING PIPES AS REQUIRED FOR CONSTRUCTION. LIMITS OF DEMOLITION ARE NOT SHOWN AND ARE TO BE ESTABLISHED BY THE CONTRACTOR. CONTRACTOR TO SUBMIT DEMOLITION PLAN TO THE ENGINEER FOR REVIEW.
5. CONTRACTOR SHALL VERIFY ALL EXISTING DIMENSIONS AND ELEVATIONS.
6. INVERT OF JUNCTION BOX TO BE SHAPED WITH CONCRETE FILL TO EFFECT DRAINAGE TO OUTLET PIPES.

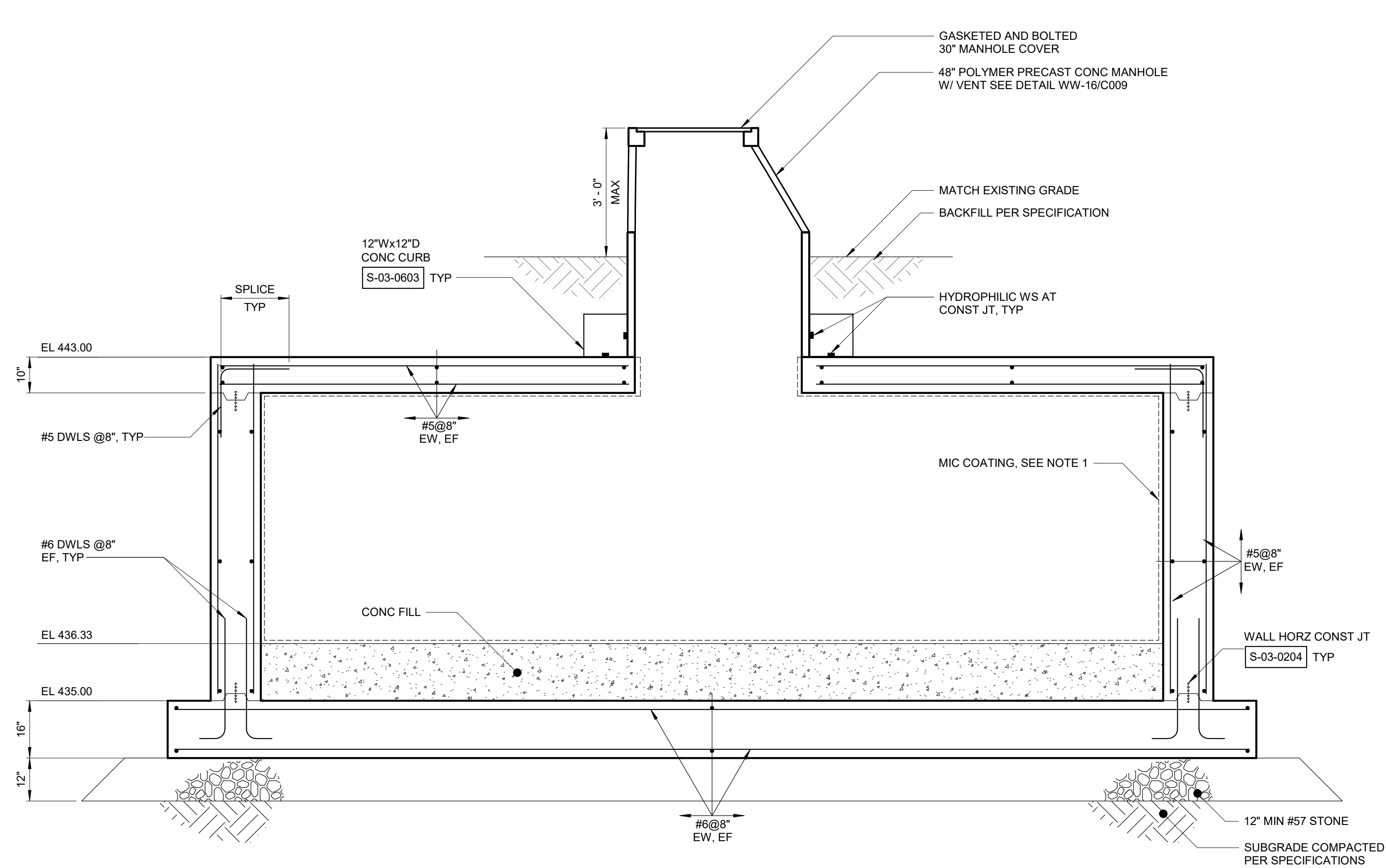

**SECTION F**  
1/2" = 1'-0"  
S007

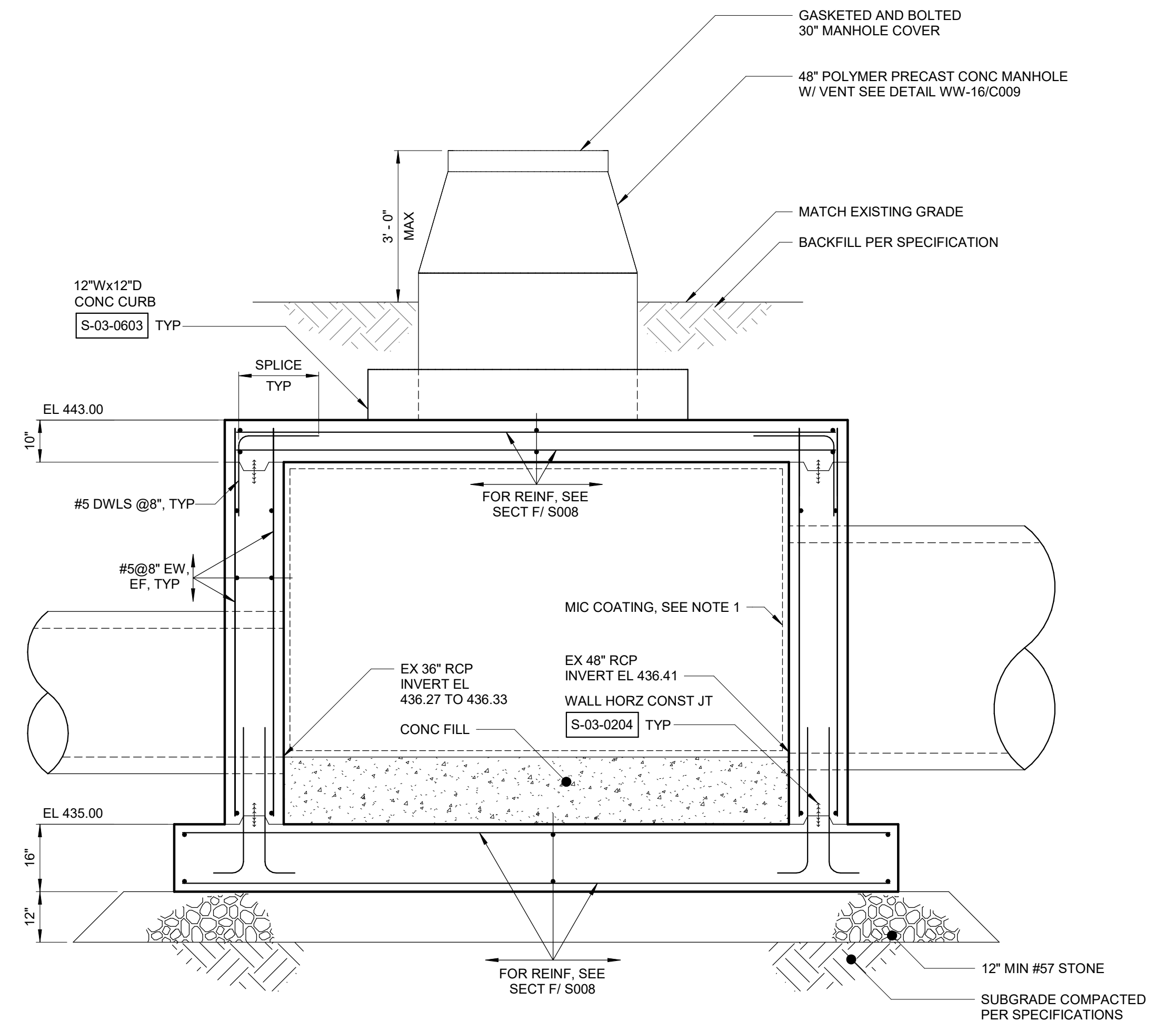

**SECTION G**  
1/2" = 1'-0"  
S007

C:\Users\bl... \Documents\6006-000-HRS\MS-S\_Notes\sm6183\F5.rvt 4/18/2025 12:53:12 PM

PROJECT ENGINEER:	J. FORD		
DESIGNED BY:	J. FORD		
DRAWN BY:	T. JOUDEH		
CHECKED BY:	F. POWELL		
IF THIS BAR DOES NOT MEASURE 1" THEN DRAWING IS NOT TO FULL SCALE	0 1/2" 1"		
REV	ISSUED FOR	DATE	BY

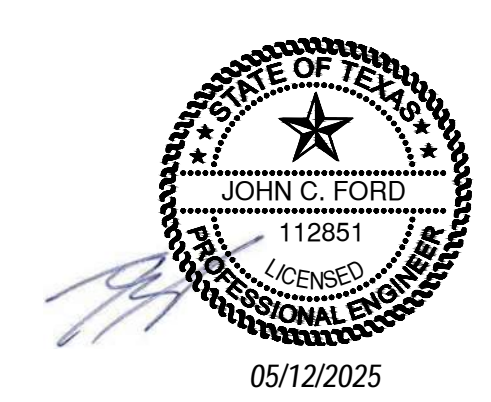

**Hazen**  
HAZEN AND SAWYER  
8150 NORTH CENTRAL EXPRESSWAY  
TOWER II SUITE 700  
DALLAS, TEXAS 75206  
TBPELS Reg. No. F-13618

**MESQUITE**  
T E X A S  
Real. Texas. Flavor.  
CITY OF MESQUITE  
TEXAS  
SAMUELL PARKS FARMS/SCYENE  
SEWER MAIN REPAIR/REHABILITATION

STRUCTURAL  
JUNCTION BOX SM 6183 SECTIONS

DATE:	APRIL 2025
HAZEN NO.:	60006-000
CONTRACT NO.:	2025-073
DRAWING NUMBER:	S008

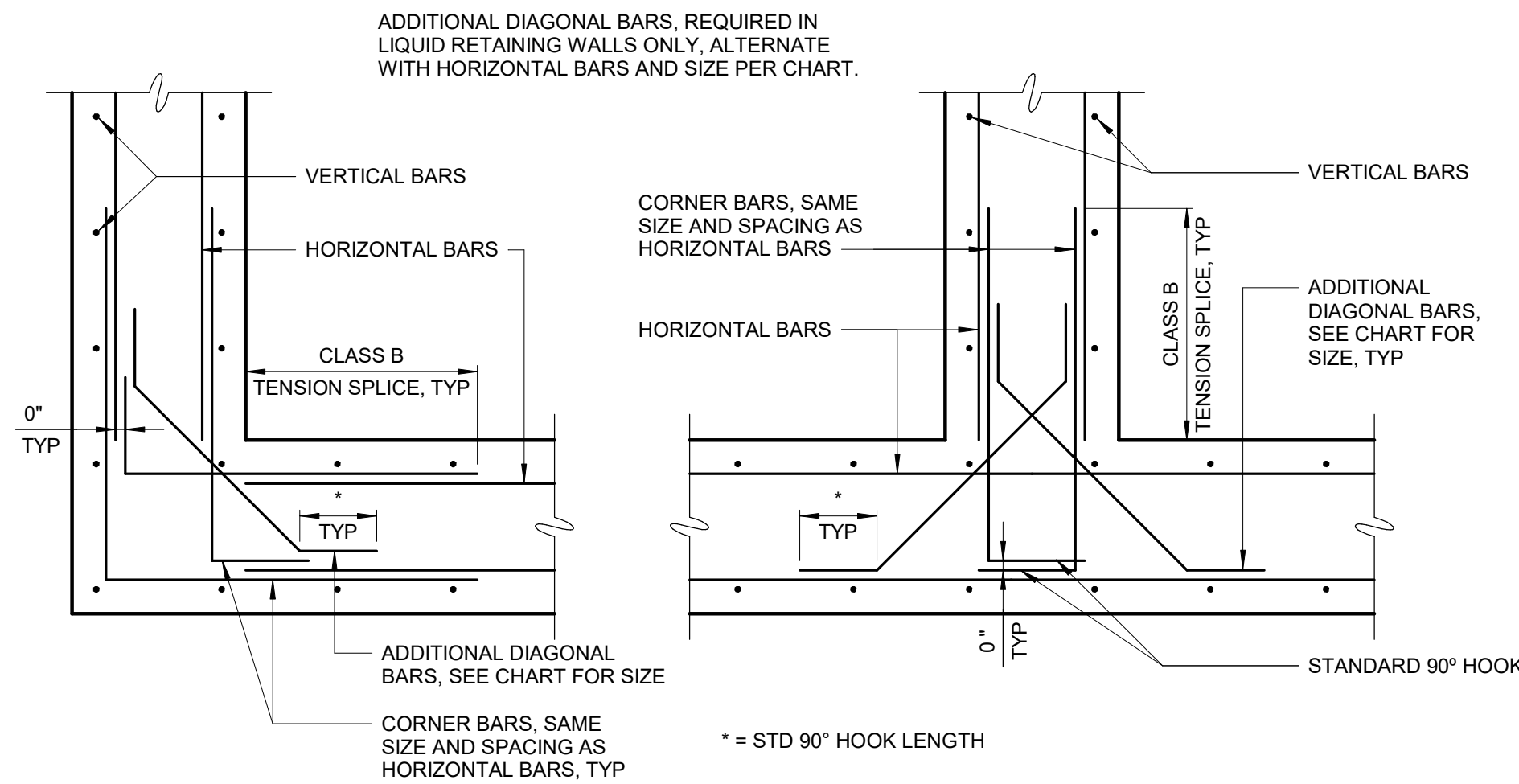

DIAGONAL BAR SIZE CHART	
BAR SIZE - HORIZONTAL REINFORCEMENT	BAR SIZE - DIAGONAL REINFORCEMENT
# 3	# 3
# 4	# 3
# 5	# 4
# 6	# 5
# 7	# 5
# 8	# 6
# 9	# 7
# 10	# 8
# 11	# 9

AT LOCATIONS WHERE DIFFERENT SIZE HORIZONTAL BARS CONVERGE, THE LARGER BAR SIZE SHALL CONTROL

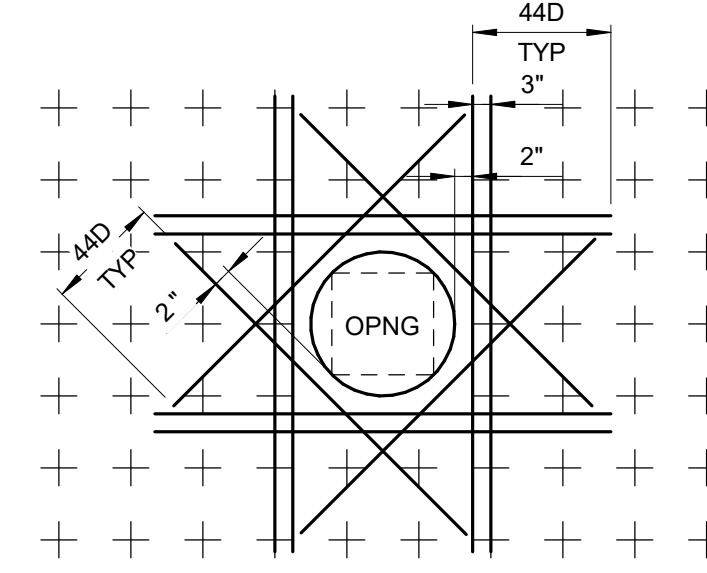

- NOTES:
- THIS DETAIL APPLIES FOR OPENINGS 8" Ø AND LARGER. FOR SMALLER OPENINGS, BEND BARS OR ADJUST SPACING OF REINFORCEMENT TO AVOID OPENING.
  - PLACE EXTRA BARS OF THE SAME SIZE AS THE INTERRUPTED BARS AT EACH SIDE OF OPENING. QUANTITY OF EXTRA BARS AT EACH SIDE SHALL EQUAL HALF THE QUANTITY OF INTERRUPTED BARS EXCEPT WHERE NOTED OTHERWISE.
  - PROVIDE ONE DIAGONAL BAR EACH SIDE OF OPENING WITH SIZE EQUAL TO MAIN REINFORCEMENT, TYPICAL EACH FACE.
  - WHERE INVERT OF OPENING IN WALL IS LESS THAN 44 BAR DIAMETERS FROM TOP OF SLAB, EXTRA REINFORCEMENT ON EACH SIDE SHALL INCLUDE DOWELS EMBEDDED INTO SLAB WITH STANDARD 90 DEGREE HOOKS TO SPLICE WITH EXTRA VERTICAL REINFORCEMENT. DOWELS SHALL ALSO STILL BE PROVIDED BELOW OPENING.
  - WHERE INVERT OF OPENING IN WALL OR SLAB IS CLOSER THAN 44 BAR DIAMETERS TO EDGE OF SLAB OR BOTTOM OF WALL, EXTRA DIAGONAL BARS MAY BE TERMINATED TWO INCHES FROM EDGE OF SLAB OR BOTTOM OF WALL. DOWELS DO NOT HAVE TO BE PROVIDED TO SPLICE WITH DIAGONAL BARS.

REINFORCING AT OPENINGS  
S-03-0109

DEVELOPMENT LENGTH OF STANDARD HOOKS  
FOR UNCOATED BARS IN TENSION

fy = 60,000 psi      fc' = 4000 psi OR GREATER

BAR SIZE	DEVELOPMENT LENGTH, $l_{dh}$	
	BASIC	W/ CONC COVER *
#3	8"	6"
#4	10"	7"
#5	1'-0"	9"
#6	1'-3"	11"
#7	1'-5"	1'-0"
#8	1'-7"	1'-2"
#9	1'-10"	1'-4"
#10	2'-1"	1'-6"
#11	2'-3"	1'-7"

\* SIDE COVER NORMAL TO PLANE OF HOOK AT LEAST 2 1/2"; AND FOR 90° HOOK, END COVER BEYOND OUTSIDE END OF HOOK AT LEAST 2".

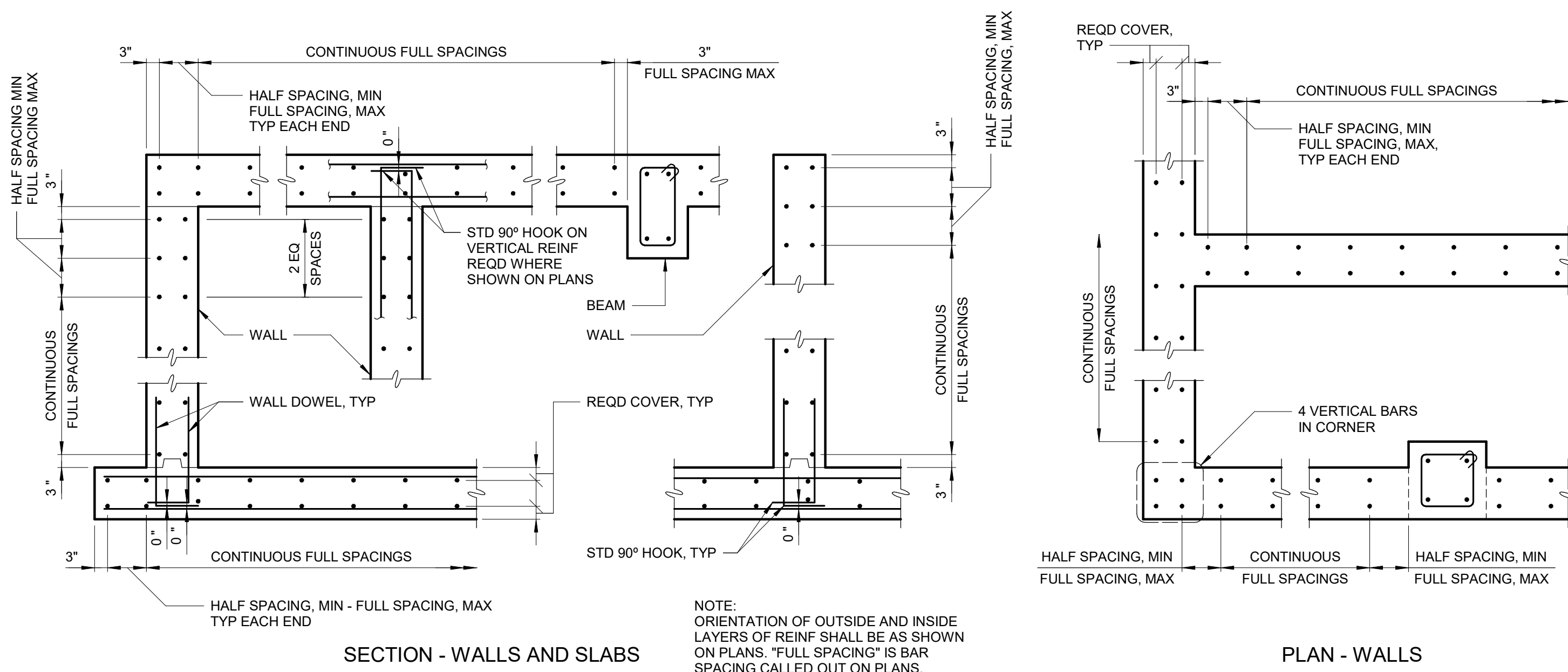
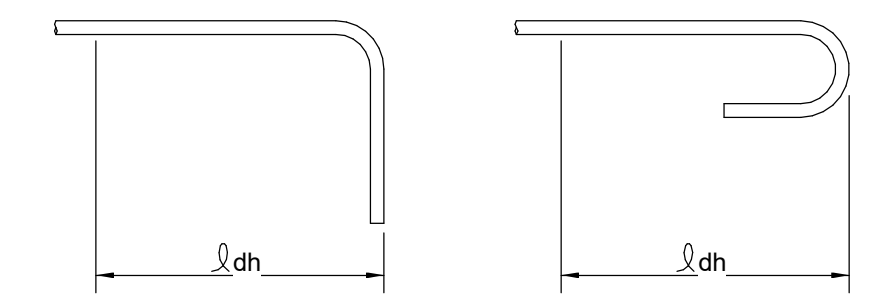

BAR PLACEMENT  
S-03-0110

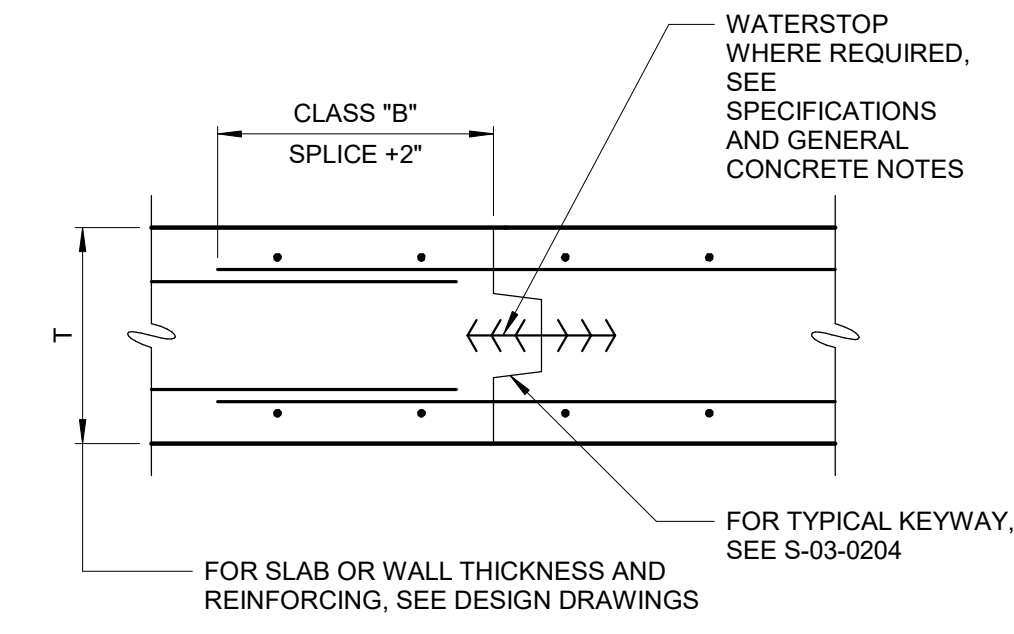

CONSTRUCTION JOINT  
S-03-0203

BASIC DEVELOPMENT LENGTH AND SPLICE LENGTH  
FOR UNCOATED BARS IN TENSION

fy = 60,000 psi      fc' = 4000 psi OR GREATER  
CLEAR COVER ≥ 1.5 INCHES      NORMAL WEIGHT CONCRETE

BASIC DEVELOPMENT LENGTH $l_d$		BAR SIZE	CLASS B SPLICE LENGTH $1.3 \times l_d$					
CLEAR SPACING ≥ 3"	CLEAR SPACING < 3"		CLEAR SPACING ≥ 3"		CLEAR SPACING < 3"			
BASIC	TOP *	BASIC	TOP *	BASIC	TOP *	BASIC	TOP *	
1'-0"	1'-0"	1'-0"	1'-4"	# 3	1'-0"	1'-3"	1'-4"	1'-8"
1'-0"	1'-3"	1'-7"	2'-1"	# 4	1'-3"	1'-8"	2'-1"	2'-9"
1'-3"	1'-7"	2'-4"	3'-0"	# 5	1'-7"	2'-0"	3'-0"	3'-11"
1'-6"	1'-11"	3'-1"	4'-0"	# 6	1'-11"	2'-5"	4'-0"	5'-2"
2'-5"	3'-1"	4'-11"	6'-4"	# 7	3'-1"	4'-0"	6'-4"	8'-3"
3'-0"	3'-11"	6'-0"	7'-9"	# 8	3'-11"	5'-1"	7'-9"	10'-1"
3'-8"	4'-9"	6'-9"	8'-9"	# 9	4'-9"	6'-3"	8'-9"	11'-4"
4'-6"	5'-10"	7'-7"	9'-10"	# 10	5'-10"	7'-7"	9'-10"	12'-9"
5'-5"	7'-0"	8'-5"	10'-11"	# 11	7'-0"	9'-1"	10'-11"	14'-2"

\* TOP REINFORCEMENT IS ANY HORIZONTAL REINFORCEMENT SO PLACED THAT MORE THAN 12 INCHES OF FRESH CONCRETE IS CAST IN THE MEMBER BELOW THE REINFORCEMENT.  
\*\* FOR MATERIALS OR CONDITIONS DIFFERENT FROM THOSE STATED, LENGTHS SHOWN IN CHART SHALL BE MODIFIED TO CONFORM TO THE PROVISIONS OF ACI 318-14, SECTION 25.3.

C:\Users\blorrenz\Documents\6006-000-HRSMRS-S\_Normasn\CBF15.rvt 4/18/2025 12:53:13 PM

REV	ISSUED FOR	DATE	BY

PROJECT ENGINEER:	J. FORD
DESIGNED BY:	J. FORD
DRAWN BY:	B. LORENZEN
CHECKED BY:	F. POWELL
IF THIS BAR DOES NOT MEASURE 1" THEN DRAWING IS NOT TO FULL SCALE	
0    1/2"    1"	

**Hazen**  
HAZEN AND SAWYER  
8150 NORTH CENTRAL EXPRESSWAY  
TOWER II SUITE 700  
DALLAS, TEXAS 75206  
TBPELS Reg. No. F-13618

**MESQUITE**  
T E X A S  
Real. Texas. Flavor.

CITY OF MESQUITE  
TEXAS

SAMUELL PARKS FARMS/SCYENE  
SEWER MAIN REPAIR/REHABILITATION

STRUCTURAL STANDARD DETAILS  
SHEET 1

DATE:	APRIL 2025
HAZEN NO.:	60006-000
CONTRACT NO.:	2025-073
DRAWING NUMBER:	SD1

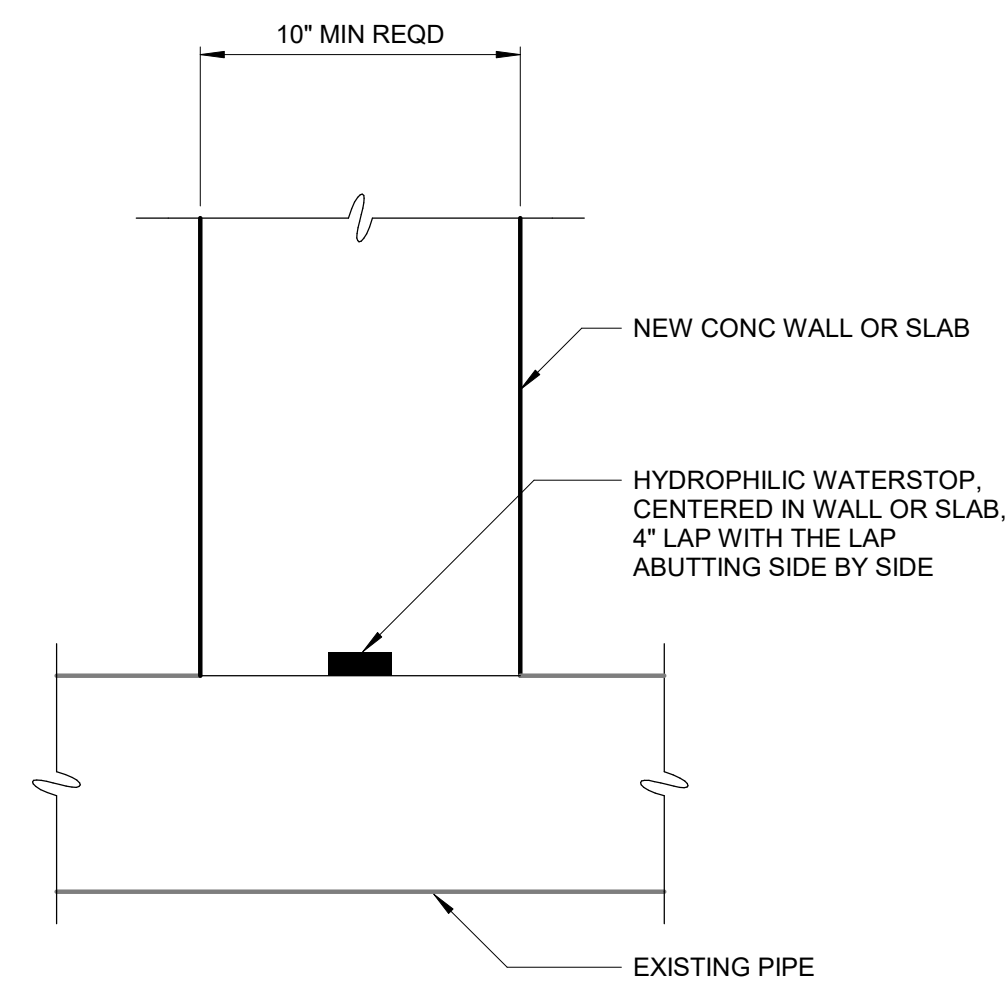

HYDROPHILIC WATERSTOP  
CONNECTION AROUND EXISTING PIPE  
S-03-0305

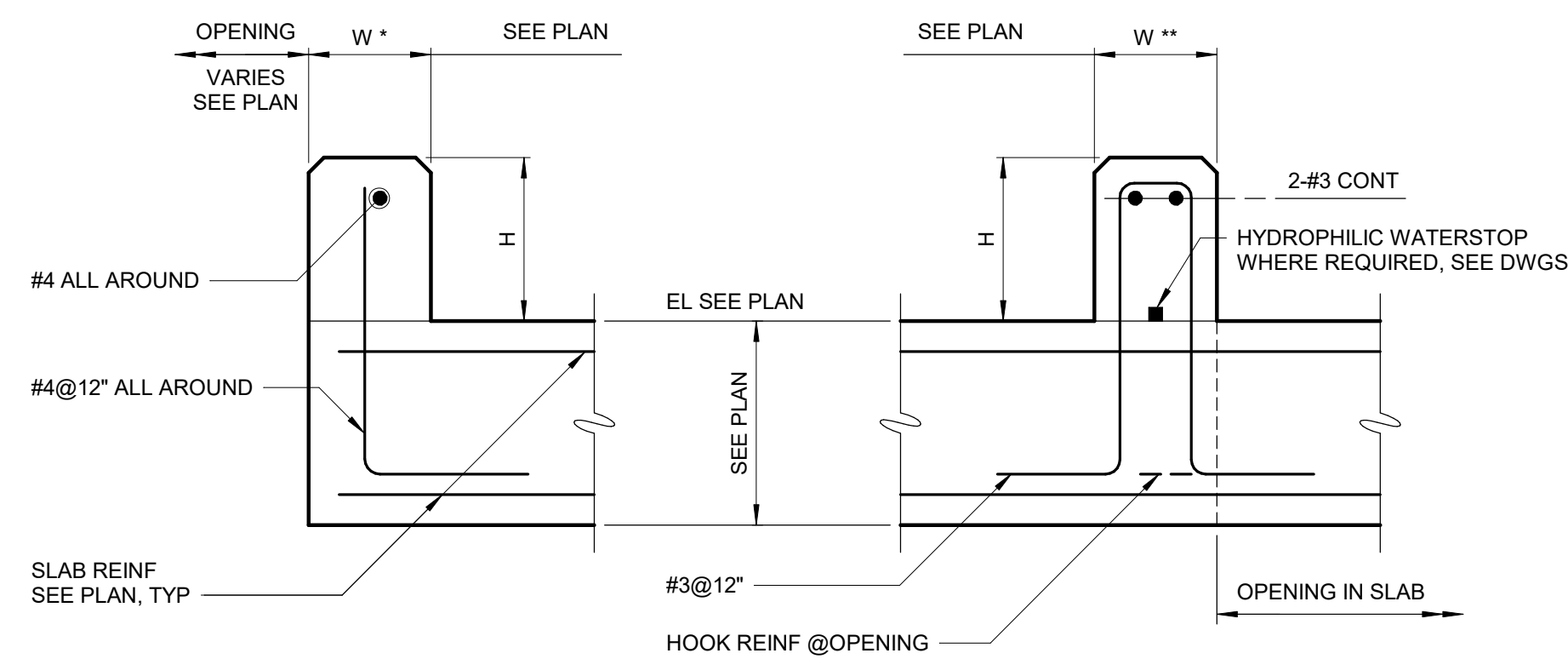

NOTE:  
W\* DENOTES CURBS LESS THAN 8"  
W\*\* DENOTES CURBS EQUAL TO OR GREATER THAN 8" DOWELS MAY BE CAST IN  
OR ANCHORED WITH DOWEL ADHESIVE SYSTEM WITH A 6" MINIMUM EMBEDMENT.  
WHERE FLOOR IS 8" THICK OR LESS, USE DOWELS EMBEDDED TO WITHIN 2" OF  
BOTTOM OF FLOOR SLAB.

CONCRETE CURB  
S-03-0603

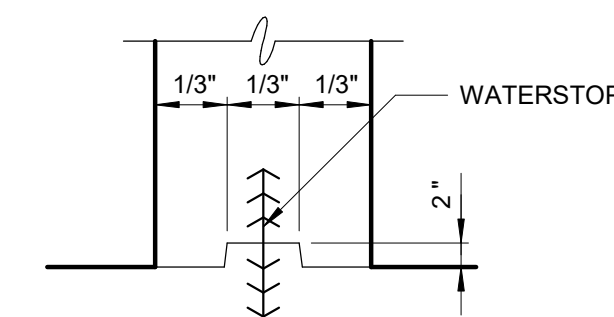

KEYWAY  
S-03-0204

C:\Users\blorenzen\Documents\6006-000-HRS\MRS-5\_Normazen\CB\F5.rvt 4/18/2025 12:53:13 PM

PROJECT ENGINEER:	J. FORD		
DESIGNED BY:	J. FORD		
DRAWN BY:	B. LORENZEN		
CHECKED BY:	F. POWELL		
IF THIS BAR DOES NOT MEASURE 1" THEN DRAWING IS NOT TO FULL SCALE			
REV	ISSUED FOR	DATE	BY

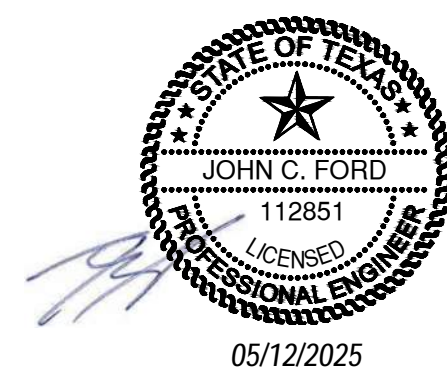

**Hazen**  
HAZEN AND SAWYER  
8150 NORTH CENTRAL EXPRESSWAY  
TOWER II SUITE 700  
DALLAS, TEXAS 75206  
TBPELS Reg. No. F-13618



CITY OF MESQUITE  
TEXAS

SAMUEL PARKS FARMS/SCYENE  
SEWER MAIN REPAIR/REHABILITATION

STRUCTURAL STANDARD DETAILS  
SHEET 2

DATE:	APRIL 2025
HAZEN NO.:	60006-000
CONTRACT NO.:	2025-073
DRAWING NUMBER:	SD2