

ORDINANCE NO. 5250

AN ORDINANCE OF THE CITY OF MESQUITE, TEXAS, AMENDING CHAPTER 5 OF THE MESQUITE CITY CODE, BY REPEALING AND REPLACING CHAPTER 5, ARTICLE IX (SWIMMING POOL AND SPA CODE), DIVISIONS 1 AND 2, IN THEIR ENTIRETY THEREBY ADOPTING THE 2024 EDITION OF THE INTERNATIONAL SWIMMING POOL AND SPA CODE (I.S.P.S.C.) AND PROVIDING CERTAIN LOCAL AMENDMENTS THERETO; PROVIDING CONFLICTS RESOLUTION, SEVERABILITY, AND SAVINGS CLAUSES; PROVIDING FOR A PENALTY NOT TO EXCEED TWO THOUSAND DOLLARS (\$2,000); PROVIDING FOR PUBLICATION OF THE CAPTION HEREOF; AND DECLARING AN EFFECTIVE DATE.

**WHEREAS**, it is the intent of the City Council of the City of Mesquite, Texas (“**City Council**”), to protect the public health, safety, and welfare; and

**WHEREAS**, the City of Mesquite, Texas, (“**City**”) is a home-rule municipality acting under its Charter adopted, and amended, by the electorate pursuant to Article 11, [Section 5](#) of the Texas Constitution and [Chapter 9](#) of the Texas Local Government Code; and

**WHEREAS**, a home-rule municipality has full power of local self-government, pursuant to Texas Local Government Code, Title 2, Subtitle D, Chapter 51, [Section 51.072\(a\)](#); and

**WHEREAS**, the City shall have the power to enact and enforce ordinances necessary to protect health, life and property and to prevent and summarily abate and remove all nuisances, and to preserve and enforce good government and order and security of the City and its inhabitants, pursuant to Article III, [Section 2](#) of the Mesquite City Charter; and

**WHEREAS**, a home-rule municipality may enforce ordinances necessary to protect health, life, and property and to preserve the good government, order, and security of the municipality and its inhabitants, pursuant to Texas Local Government Code, Title 2, Subtitle D, Chapter 54, [Section 54.004](#), as amended; and

**WHEREAS**, the City shall have the power to provide for the issuance of permits for erecting all buildings, for the inspection of the construction of buildings in respect to proper wiring for electric lights and other electrical appliances, piping for gas, flues, chimneys, plumbing, and sewer connections; and to enforce proper regulations in regard thereto; and the City shall also have the power to provide for license, permit and inspection fees, pursuant to Article III, [Section 28](#) of the Mesquite City Charter; and

**WHEREAS**, on March 17, 2026, the Building Standards Board held public hearings to discuss the adoption of the 2024 Edition of the Swimming Pool and Spa Code (“**I.S.P.S.C.**”) and to receive input from the general public and all persons who may be affected by the proposed adoption; and

**WHEREAS**, the Building Standards Board, by majority vote, has recommended the City Council adopt the 2024 Edition of the **I.S.P.S.C.** and the additions, deletions, and amendments (“**the local amendments**”) thereto, attached hereto as **EXHIBIT A**; and

**WHEREAS**, upon the favorable recommendation of the Building Standards Board, and upon full review and consideration of all matters attendant and related thereto, and after receiving input from the general public and all persons who may be affected by the proposed adoption, the City Council is of the opinion that the 2024 Edition of the **I.S.P.S.C.** and the local amendments thereto, should be approved and adopted as the Swimming Pool and Spa Code of the City of Mesquite, Texas.

**NOW, THEREFORE, BE IT ORDAINED BY THE CITY COUNCIL OF THE CITY OF MESQUITE, TEXAS:**

**SECTION 1.**

**Recitals Incorporated.**

The City Council hereby finds and determines the recitals made in the preamble of this Ordinance are true and correct, and hereby incorporates such recitals here in the body of this Ordinance as if copied in their entirety.

**SECTION 2.**

**MESQUITE CITY CODE TEXT AMENDMENT:**

**Amending Chapter 5, Article IX – Swimming Pool and Spa Code.**

The Mesquite City Code is hereby amended as identified in **EXHIBIT A** and said exhibit is attached hereto and made a part hereof, and in all other respects, said Code, Chapters, and Articles shall remain in full force and effect.

**SECTION 3.**

**Conflicts Resolution Clause.**

In the event of an irreconcilable conflict between the provisions of another previously adopted ordinance of the City of Mesquite and the provisions of this Ordinance, the provisions of this Ordinance shall be controlling.

**SECTION 4.**

**Severability Clause.**

Should any word, sentence, paragraph, subdivision, clause, phrase, or section of this Ordinance be adjudged or held to be void or unconstitutional, the same shall not affect the validity of the remaining portions of said Ordinance and the Mesquite City Code, as hereby or previously amended, which shall remain in full force and effect.

**SECTION 5. Savings Clause.**

An offense committed before the effective date of this Ordinance is governed by prior law and the provisions of the Mesquite City Code, as amended, in effect when the offense was committed, and the former law is continued in effect for this purpose.

**SECTION 6. Penalty Clause.**

Any violation of the provisions or terms of this Ordinance by any “person,” as defined in Mesquite City Code, Chapter 1, [Section 1-2](#), shall be deemed a Class C Misdemeanor criminal offense, and upon conviction thereof, shall be subject to a penalty of fine, or any other general penalties, as provided in Mesquite City Code, Chapter 1, [Section 1-6](#), as amended.

**SECTION 7. Publication.**

This Ordinance shall be published in the City’s official newspaper in accordance with Mesquite City Charter, Article IV, [Section 24](#).

**SECTION 8. Effective Date.**

8.01. In accordance with Texas Local Government Code, Title 7, Subtitle A, Chapter 214, Subchapter G, § 214.218 (Immediate Effect of Certain Codes or Provisions Delayed), the City shall delay implementing and enforcing this ordinance for at least 30 days after final adoption.

8.02. This ordinance shall become effective and be in force from and after **July 1, 2026**.

**DULY PASSED AND APPROVED BY THE CITY COUNCIL OF THE CITY OF MESQUITE, TEXAS, ON THE 18TH DAY OF MAY 2026.**

Signed by:  
*Daniel Aleman*  
D999585317D142B...

---

**Daniel Alemán, Jr.**  
**Mayor**

**ATTEST:**

DocuSigned by:  
*Sonja Land*  
C2518095973F46A...

---

**Sonja Land**  
**City Secretary**

**APPROVED AS TO LEGAL FORM:**

Signed by:  
*David L. Paschall*  
666E18891208434...

---

**David L. Paschall**  
**City Attorney**

## MESQUITE CITY CODE

\* \* \*

### Chapter 5 – BUILDINGS AND CONSTRUCTION

\* \* \*

### ARTICLE IX. – SWIMMING POOL AND SPA CODE

**Editor's note:**

[Existing Chapter 5, Article IX (Swimming Pool and Spa Code), Divisions 1 and 2, shall be repealed in their entirety and replaced with the following text.]

#### DIVISION 1. - Generally

**Sec. 5-401. Short title.**

This article shall be known and cited as the "Mesquite Swimming Pool and Spa Code " and may hereinafter be referred to in this article as "this code."

(Ord. No. 4801, § 2(Exh. H), 9-21-20)

**Sec. 5-402. Adopted.**

The International Swimming Pool and Spa Code (I.S.P.S.C.), 2024 Edition, a publication of the International Code Council (I.C.C.), is hereby adopted by reference and incorporated herein to the same extent as if such code were copied verbatim in this Section, subject to the deletions, additions, and amendments ("the local amendments") as may be prescribed in this article. A copy of the International Swimming Pool and Spa Code, 2024 Edition, and the local amendments thereto shall be maintained in the Office of the City Secretary.

(Ord. No. 4801, § 2(Exh. H), 9-21-20)

**Sec. 5-403. Penalties.**

(a) *Criminal penalty.* Any violation of the provisions or terms of this article by any "person," as defined in Mesquite City Code, Chapter 1, [Section 1-2](#), shall be deemed a Class C Misdemeanor criminal offense, and upon conviction thereof, shall be subject to a penalty of fine, or any other general penalties, as provided in Mesquite City Code, Chapter 1, [Section 1-6](#), as amended.

(b) *Civil penalty.* The City may file any other civil actions for enforcement of this article as authorized by law.

(Ord. No. 4801, § 2(Exh. H), 9-21-20)

**Charter reference—** Enforcement of ordinances, Art. III, § 28.

**Cross reference—** General penalties, [§ 1-6](#).

**State Law reference—** General Enforcement Authority of Municipalities;

Penalty, V.T.C.A. Local Government Code, § 54.001;

Civil Action, V.T.C.A. Local Government Code, § 54.012;

Civil Penalty, V.T.C.A. Local Government Code, § 54.017.

**Secs. 5-404, 5-405. – Reserved.**

## DIVISION 2. – AMENDMENTS

### Sec. 5-406. Local Amendments to the International Swimming Pool and Spa Code, 2024 Edition.

- (a) *Specific code provisions.* Amendments included in this section are intended to be specific code provisions. If there is a conflict between a provision in the published International Swimming Pool and Spa Code (I.M.C.), 2024 Edition, and this section, the specific provisions of this section shall control.
- (b) *Table of the local amendments.* The following table contains the local amendments to the I.S.P.S.C., 2024 Edition.
  - (1) Table Legend.
    - a. Column 1: Item Reference Number
    - b. Column 2: Related I.S.P.S.C. Code Section Number and Title
    - c. Column 3: Local Amendment to I.S.P.S.C.
    - d. (...): Dots (...) (i.e., an ellipsis) indicate the omission of intact and unchanged text which has not been reproduced for efficiency purposes. It is intended that the text in the I.S.P.S.C., not set forth in this section and instead denoted by dots (...), shall remain intact and unchanged from the language existing prior to adoption of this section.
    - e. ( \* \* \* ): Asterisks ( \* \* \* ) indicate the omission of intact and unchanged text which has not been reproduced for efficiency purposes. It is intended that the text in the I.S.P.S.C., not set forth in this section and instead denoted by asterisks ( \* \* \* ), shall remain intact and unchanged from the language existing prior to adoption of this section.
  - (2) TABLE OF LOCAL AMENDMENTS TO THE 2024 INTERNATIONAL SWIMMING POOL AND SPA CODE

*[The remainder of this page is intentionally left blank.]*

**EXHIBIT A TO ORDINANCE NO. 5250.**

**Mesquite City Code, Ch. 5 – Buildings and Construction, Article IX – Swimming Pool and Spa Code, Divisions 1 and 2**

Building Standards Board Meeting Date: March 17, 2026 | City Council Meeting Date: May 18, 2026

*[Editor’s Note: Repeal the existing Table and replace with the following new text to now read as follows:]*

No.	ISPSC Code Section No. Title	Local Amendment to ISPSC
01	ISPSC 101.1 Title.	<p><i>Amend section in its entirety to read as follows:</i></p> <p><b>101.1: Title.</b> These regulations shall be known as the Swimming Pool Code of the City of Mesquite, Texas, ("Mesquite Swimming Pool and Spa Code") and may hereinafter be referred to as "this code."</p>
02	ISPSC 102.9 Other Laws.	<p><i>Amend section in its entirety to read as follows:</i></p> <p><b>Section 102.9: Other laws.</b> The provisions of this code shall not be deemed to nullify any provisions of local, state or federal law, to include but not limited to:</p> <ol style="list-style-type: none"> <li>1. Texas Department of State Health Services (TDSHS); Standards for Public Pools and Spas §265.181 through §265.198, (TDSHS rules do not apply to pools serving one- and two-family dwellings or townhouses).</li> <li>2. Texas Department of Licensing and Regulation (TDLR); 2012 Texas Accessibility Standards (TAS), TAS provide the scoping and technical requirements for accessibility for Swimming Pool, wading pools and spas and shall comply with 2012 TAS, Section 242. (TAS rules do not apply to pools serving one- and two-family dwellings or townhouses).</li> </ol> <p><b>Exception:</b> Elements regulated under Texas Department of Licensing and Regulation (TDLR) and built in accordance with TDLR approved plans, including any variances or waivers granted by the TDLR, shall be deemed to be in compliance with the requirements of this Chapter.</p>
03	ISPSC 105.4.3 Expiration.	<p><i>Amend section in its entirety to read as follows:</i></p> <p><b>105.4.3: Expiration.</b> An application for a permit for any proposed work shall be deemed to have been abandoned 45-days after the date of filing, unless such application has been pursued in good faith or a permit has been issued; except that the Building Official is authorized to grant one or more extensions of time for additional periods not exceeding 45-days each. The extension shall be requested in writing and justifiable cause demonstrated.</p>
04	ISPSC 109.1 Fees.	<p><i>Amend by adding a sentence [after the first and only sentence of the section] to read as follows:</i></p> <p><b>109.1: Fees</b></p> <p>* * *</p> <p>See Mesquite City Code, <a href="#">Appendix D - Comprehensive Fee Schedule</a>, for applicable fees.</p>

05	ISPSC 109.6 Refunds.	<p><i>Amend section in its entirety to read as follows:</i></p> <p><b>109.6: Refunds.</b>                  In the case where a fee was paid or collected erroneously, the Building Official shall authorize a one hundred percent (100%) refund of said fee. In the case where a fee was paid or collected and when no work was performed under a permit issued in accordance with this Code, the Building Official shall authorize a partial refund, of not more than eighty percent (80%) of the permit fee, in accordance with this Section. The Building Official shall not authorize refunding of any fee paid except on written request filed by the original permittee not later than 180-days from the date of fee payment.</p>
06	ISPSC Section 112: Appeals.	<p><i>Amend title and section in its entirety to read as follows:</i></p> <p><b>SECTION 112: APPEALS</b></p> <p><b>112.1: General.</b>                  Except as otherwise provided, any person shall have the right to appeal an administrative decision of the Building Official, Fire Official, or any other City official to the Building Standards Board, when said decision is relative to the application, enforcement, or interpretation of this Code.</p> <p>The Building Standards Board is established in Mesquite City Code, <a href="#">Chapter 20</a>, Article IV, <a href="#">Division 4</a> (Building Standards Board).</p> <p>The process and procedures for appealing an administrative decision are set forth in <a href="#">Chapter 5, Article XIII</a> (Appeals of Administrative Decisions to Building Standards Board).</p> <p><b>Appeal of an Administrative Decision relative to a Certificate of Occupancy:</b></p> <p>When an appeal of an administrative decision is relative to a Certificate of Occupancy the appeal shall be to the Board of Adjustment for its denial, revocation, suspension, or otherwise (in accordance with Mesquite Zoning Ordinance, Part 5, 5-100, <a href="#">Section 5-106</a> (Certificate of Occupancy)).</p> <p>The process and procedures for appealing an administrative decision relative to a Certificate of Occupancy, or any other administrative decision made under the Mesquite Zoning Ordinance, are set forth in Mesquite Zoning Ordinance, Part 5, 5-200, <a href="#">Section 5-210</a> (Appeals of Administrative Decisions to Board of Adjustment).</p>
07	ISPSC 113.1 Unlawful Acts.	<p><i>Amend section in its entirety to read as follows:</i></p> <p><b>113.1: Unlawful acts.</b>                  It shall be unlawful for any person, firm, corporation, or entity to erect, construct, alter, extend, repair, move, remove, demolish, or occupy any building, structure, or equipment regulated by this code, or cause same to be done, in conflict with, or in violation of, any of the provisions of this code.</p>

**EXHIBIT A TO ORDINANCE NO. 5250.**

**Mesquite City Code, Ch. 5 – Buildings and Construction, Article IX – Swimming Pool and Spa Code, Divisions 1 and 2**

Building Standards Board Meeting Date: March 17, 2026 | City Council Meeting Date: May 18, 2026

08	ISPSC 113.2 Notice of Violation.	<p><i>Amend section in its entirety to read as follows:</i></p> <p><b>113.2: Notice of violation.</b></p> <p>The Building Official is authorized to serve a notice of violation or order on the owner of the premises, or any person, firm, corporation, or other entity responsible for the erection, construction, alteration, extension, repair, moving, removal, demolition, or occupancy of a building or structure, in violation of the provisions of this code, or in violation of a permit or certificate issued under the provisions of this code. Such order may direct the discontinuance of the illegal action or condition and the abatement of the violation.</p>
09	ISPSC 113.3 Prosecution of Violation.	<p><i>Amend section in its entirety to read as follows:</i></p> <p><b>113.3: Prosecution of violation.</b></p> <p>Failure to promptly comply with notice of violation issued by the Building Official shall constitute a separate violation of this code and may be prosecuted as such by the City. This section shall not be construed as requiring notification, or any other condition, to any proceeding seeking to address any violation of the provisions of this code.</p>
10	ISPSC 113.4 Violation Penalties.	<p><i>Amend section in its entirety to read as follows:</i></p> <p><b>113.4: Violation penalties.</b></p> <p>Any person who shall violate a provision of this code or shall fail to comply with any of the requirements thereof or who shall erect, install, alter or repair a pool or spa in violation of the approved construction documents or directive of the code official, or of a permit or certificate issued under the provisions of this code may be punishable for each day of the violation set forth by the authority having jurisdiction.</p>
11	ISPSC Section 202: General Definitions	<p><i>Amend section by changing the definition for "Code Official" to read as follows:</i></p> <p><b>CODE OFFICIAL.</b></p> <p>The Building Official, or other authority designated by the Building Official, charged with the administration and enforcement of this Code.</p>
12	ISPSC 305.1 General.	<p><i>Amend section in its entirety to read as follows:</i></p> <p><b>305.1: General.</b></p> <p>The provisions of this section shall apply to the design of barriers for restricting entry into areas having pools and spas. In only one-and two-family dwellings and townhouses, where spas or hot tubs are equipped with a lockable safety cover complying with ASTM F1346 and swimming pools are equipped with a powered safety cover that complies with ASTM F1346, the areas where those spas, hot tubs, or pools are located shall not be required to comply with Sections 305.2 through 305.7.</p>

Mesquite City Code, Ch. 5 – Buildings and Construction, Article IX – Swimming Pool and Spa Code, Divisions 1 and 2

Building Standards Board Meeting Date: March 17, 2026 | City Council Meeting Date: May 18, 2026

<p>13</p>	<p>ISPSC 305.2.1 Barrier Height and Clearances.</p>	<p><i>Amend section by changing #1 and adding an exception underneath #1 to read as follows:</i></p> <p><b>305.2.1: Barrier height and clearances.</b> Barrier heights and clearances shall be in accordance with all of the following:</p> <p>1. The top of the barrier shall be not less than 60 inches (1524 mm) above grade where measured on the side of the barrier that faces away from the pool or spa. Such height shall exist around the entire perimeter of the barrier and for a distance of 3 feet (914 mm) measured horizontally from the outside of the required barrier.</p> <p><b>Exception:</b> For other than Public or Semi-Public swimming pools and spas, the top of the barrier shall be not less than 48 inches (1219 mm) above grade where measured on the side of the barrier that faces away from the pool or spa. Such height shall exist around the entire perimeter of the barrier and for a distance of 3 feet (914 mm) measured horizontally from the outside of the required barrier.</p> <p style="text-align: center;">* * *</p> <p>#2 through #4 [<i>Remain unchanged.</i>]</p>
<p>14</p>	<p>305.2.8.1 Chain Link Fencing Prohibited.</p>	<p><i>Add new section to read as follows:</i></p> <p><b>305.2.8.1: Chain link fencing prohibited.</b> Chain link fencing is not permitted as a barrier in public pools built after January 1, 1994.</p>
<p>15</p>	<p>ISPSC 305.4 Structure Wall as a Barrier.</p>	<p><i>Amend section as follows:</i></p> <p><b>305.4: Structure wall as a barrier.</b> Where a wall of a dwelling or structure of a one- and two-family dwelling or townhouse or its accessory structure serves as part of a barrier and where doors or windows provide direct access to the pool or spa through that wall, one of the following shall be required:</p> <p style="text-align: center;">* * *</p> <ol style="list-style-type: none"> <li>1. [Unchanged]</li> <li>2. [Unchanged]</li> <li>3. [Unchanged]</li> <li>4. [Unchanged]</li> <li>5. [Unchanged]</li> <li>6. [Unchanged]</li> </ol>

**EXHIBIT A TO ORDINANCE NO. 5250.**

**Mesquite City Code, Ch. 5 – Buildings and Construction, Article IX – Swimming Pool and Spa Code, Divisions 1 and 2**

Building Standards Board Meeting Date: March 17, 2026 | City Council Meeting Date: May 18, 2026

16	ISPSC 305.6 Natural Barriers Used in a One- and Two-Family Dwelling or Townhouse	<p><i>Amend section in its entirety to read as follows:</i></p> <p><b>305.6: Natural barriers used in a one- and two-family dwelling or townhouse.</b> In the case where the pool or spa area abuts the edge of a lake or other natural body of water, public access is not permitted or allowed along the shoreline, and required barriers extend to and beyond the water’s edge a minimum of eighteen (18) inches, a barrier is not required between the natural body of water shoreline and the pool or spa.</p>
17	ISPSC 307.1.5 Accessibility.	<p><i>Add exception to read as follows:</i></p> <p><b>307.1.5: Accessibility.</b></p> <p style="text-align: center;">* * *</p> <p><b>Exception:</b> Components of projects regulated by and registered with Architectural Barriers Division of Texas Department of Licensing and Regulation shall be deemed to be in compliance with the requirements of this chapter.</p>
18	ISPSC 307.2.2.2 Adjacency to Structural Foundation.	<p><i>Add new section to read as follows:</i></p> <p><b>307.2.2.2: Adjacency to Structural Foundation:</b> Depth of the swimming pool and spa shall maintain a ratio of 1:1 from the nearest building foundation or footing of a retaining wall.</p> <p><b>Exception:</b> A sealed engineered design drawing of the proposed new structure shall be submitted for approval.</p>
19	ISPSC 311.1 General.	<p><i>Amend section as follows:</i></p> <p><b>311.1: General.</b> Suction entrapment avoidance for pools and spas shall be provided in accordance with APSP 7 (ANSI/PHTA/ICC 7), or for public swimming pools in accordance with State of Texas Rules for Public Swimming Pools and Spas, Title 25 TAC Chapter 265 Subchapter L, Rule §265.190.</p> <p style="text-align: center;">* * *</p> <p style="text-align: center;"><i>[Exceptions remain unchanged.]</i></p>
20	ISPSC 314.7 Emergency Shutoff Switch.	<p><i>Amend section in its entirety and delete the exception to read as follows:</i></p> <p><b>314.7: Emergency shutoff switch.</b> A clearly labeled emergency shutoff or control switch for the purpose of stopping the motor(s) that provide power to the recirculation system and jet system shall be installed at a point readily accessible to the users and not less than 1.5 m (5 ft.) away, adjacent to, and within sight of the spa or hot tub. This requirement shall not apply to one- and two-family dwellings and townhouses.</p>

21 ISPSC  
402.12 Water  
Envelopes.

Amend section in its entirety to read as follows:

**402.12: Water envelopes.**  
The minimum diving water envelopes shall be in accordance with Table 402.12 Texas department of State Health services, Administrative Code Title 25, Chapter 265, Section 186 (e) and Figure: 25 TAC 256.186 (e) (6).

[Delete Table 402.12]  
[Delete Figure 402.12]

ADD: Figure: 25 TAC §265.186 (e) (6)

Maximum Diving Board Height Over Water	¼ Meter	1 Meter	3 Meters
Max. Diving Board Length	12 ft.	16 ft.	16 ft.
Minimum Diving Board Overhang	2 ft. 6 in.	5 ft.	5 ft.
D1 Minimum	8 ft. 6 in.	11 ft. 2 in.	12 ft. 2 in.
D2 Minimum	9 ft.	10 ft. 10 in.	11 ft. 10 in.
D3 Minimum	4 ft.	6 ft.	6 ft.
L1 Minimum	4 ft.	5 ft.	5 ft.
L2 Minimum	12 ft.	16 ft. 5 in.	19 ft. 9 in.
L3 Minimum	14 ft. 10 in.	13 ft. 2 in.	13 ft. 11 in.
L4 Minimum	30 ft. 10 in.	34 ft. 7 in.	38 ft. 8 in.
L5 Minimum	8 ft.	10 ft.	13 ft.
H Minimum	16 ft.	16 ft.	16 ft.
From Plumbet to Pool Wall at Side	9 ft.	10 ft.	11 ft. 6 in.
From Plumbet to Adjacent Plumbet	10 ft.	10 ft.	10 ft.

H (Overhead Obstruction or Ceiling)

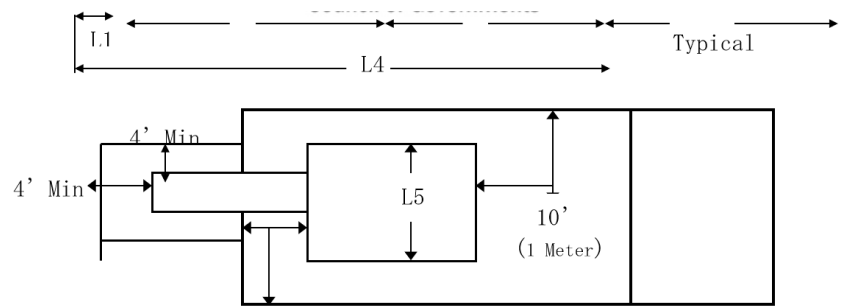

**EXHIBIT A TO ORDINANCE NO. 5250.**

**Mesquite City Code, Ch. 5 – Buildings and Construction, Article IX – Swimming Pool and Spa Code, Divisions 1 and 2**

Building Standards Board Meeting Date: March 17, 2026 | City Council Meeting Date: May 18, 2026

22	ISPSC 402.13 Ladders For Diving Equipment.	<p><i>Amend section by adding a sentence after the second sentence to read as follows:</i></p> <p><b>402.13: Ladders for diving equipment.</b> Ladders shall be provided with two grab rails or two handrails. There shall be uniform...</p> <p style="text-align: center;">* * *</p> <p>Supports, platforms, steps, and ladders for diving equipment shall be designed to carry the anticipated loads. Steps and ladders shall be of corrosion-resistant material, easily cleanable and with slip-resistant tread.</p> <p><b>Exception:</b> <i>[Remains unchanged.]</i></p>
23	ISPSC 411.2.1 Tread Dimensions and Area.	<p><i>Amend section in its entirety to read as follows:</i></p> <p><b>411.2.1: Tread dimensions and area.</b> Treads shall have a minimum unobstructed horizontal depth (i.e., horizontal run) of 12 inches and a minimum width of 20 inches.</p>
24	ISPSC 411.2.2 Risers.	<p><i>Amend section in its entirety to read as follows:</i></p> <p><b>411.2.2: Risers.</b> Risers for steps shall have a maximum uniform height of 10 inches, with the bottom riser height allowed to taper to zero.</p>
25	ISPSC 411.5.1 Swim Outs.	<p><i>Amend section as follows:</i></p> <p><b>411.5.1: Swim outs.</b> Swim outs, located in either the deep or shallow area of a pool, shall comply with all of the following:</p> <ol style="list-style-type: none"> <li>1. <i>[Unchanged]</i></li> <li>2. <i>[Unchanged]</i></li> <li>3. <i>[Unchanged]</i></li> <li>4. The leading edge shall be visibly set apart and provided with a horizontal solid or broken stripe at least 1 inch wide on the top surface along the front leading edge of each step. This stripe shall be plainly visible to persons on the pool deck. The stripe shall be a contrasting color to the background on which it is applied, and the color shall be permanent in nature and shall be a slip-resistant surface.</li> </ol>

**EXHIBIT A TO ORDINANCE NO. 5250.**

**Mesquite City Code, Ch. 5 – Buildings and Construction, Article IX – Swimming Pool and Spa Code, Divisions 1 and 2**

Building Standards Board Meeting Date: March 17, 2026 | City Council Meeting Date: May 18, 2026

26	ISPSC 411.5.2 Underwater Seats and Benches.	<p><i>Amend section as follows:</i></p> <p><b>411.5.2: Underwater Seats and Benches.</b> Underwater seats and benches, whether used alone or in conjunction with pool stairs, shall comply with all of the following:</p> <ol style="list-style-type: none"> <li>1. [Unchanged]</li> <li>2. [Unchanged]</li> <li>3. [Unchanged]</li> <li>4. [Unchanged]</li> <li>5. The leading edge shall be visually set apart and provided with a horizontal solid or broken stripe at least 1 inch wide on the top surface along the front leading edge of each step. This stripe shall be plainly visible to persons on the pool deck. The stripe shall be a contrasting color to the background on which it is applied, and the color shall be permanent in nature and shall be a slip-resistant surface.</li> <li>6. [Unchanged]</li> <li>7. [Unchanged]</li> </ol>
27	ISPSC 610.5.1 Uniform Height of 10 inches	<p><i>Amend title and section in its entirety to read as follows:</i></p> <p><b>610.5.1: Uniform height of 10 inches.</b> Except for the bottom riser, risers at the centerline shall have a maximum uniform height of 10 inches (254 mm). The bottom riser height shall be permitted to vary from the other risers.</p>
28	ISPSC 804.1 General.	<p><i>Amend section as follows:</i></p> <p><b>804.1: General.</b> The minimum diving water envelopes shall be in accordance with Table 804.1 and Figure 804.1, or the manufacturer’s specifications, whichever is greater. Negative construction tolerances shall not be applied to the dimensions of the minimum diving water envelopes given in Table 804.1.</p> <p style="text-align: center;"><i>[Table and Figures shall remain unchanged.]</i></p>

(Ord. No. 4801, § 2(Exh. H), 9-21-20; Ord. No. 4894, § 7(Exh. F), 9-7-21; Ord. No. 5061, § 3(Exh. B), 9-5-23)

**Secs. 5-407—5-410. – Reserved.**

\* \* \*