

ORDINANCE NO. 4889  
File No. Z0521-0196

AN ORDINANCE AMENDING THE MESQUITE ZONING ORDINANCE BY APPROVING A CHANGE OF ZONING FROM AGRICULTURE TO PLANNED DEVELOPMENT – SINGLE FAMILY RESIDENTIAL WITH AN UNDERLYING ZONING DISTRICT OF R3 TO ALLOW A SINGLE-FAMILY SUBDIVISION ON PROPERTY LOCATED AT 2400, 2402, 2404, AND 2800 MESQUITE VALLEY ROAD; REPEALING ALL ORDINANCES IN CONFLICT WITH THE PROVISIONS OF THIS ORDINANCE; PROVIDING A SEVERABILITY CLAUSE; PROVIDING A PENALTY NOT TO EXCEED \$2,000.00; AND PROVIDING AN EFFECTIVE DATE.

WHEREAS, the Planning and Zoning Commission and the City Council, in compliance with the Charter of the City of Mesquite, state laws and the zoning ordinance, have given the required notices and held the required public hearings regarding the rezoning of the subject property; and

WHEREAS, the City Council finds that it is in the public interest to grant this change in zoning.

NOW, THEREFORE, BE IT ORDAINED BY THE CITY COUNCIL OF THE CITY OF MESQUITE, TEXAS:

SECTION 1. The subject property (“**Property**”) is described as being approximately 51.65 acres of undeveloped land more fully described in the legal descriptions attached as Exhibit A, and located at 2400, 2402, 2404, and 2800 Mesquite Valley Road, Mesquite, Dallas County, Texas.

SECTION 2. The Mesquite Zoning Ordinance is amended by approving a change of zoning for the Property from Agriculture to Planned Development – Single Family Residential, to allow for development of a single-family subdivision subject to the Planned Development Standards, the Concept Plan, and the Typical Street Section and Utility Location, attached hereto as Exhibits B, C, and D respectively, and incorporated herein by reference. Notwithstanding the foregoing, the underlying zoning for the Property shall be Mesquite Zoning Ordinance R-3 single family such that all R-3 single family district uses and standards apply to the Property except as expressly modified by this Planned Development Ordinance.

SECTION 3. All ordinances, or portions thereof, of the City of Mesquite in conflict with the provisions of this ordinance, to the extent of such conflict are hereby repealed; otherwise, they shall remain in full force and effect.

SECTION 4. The Property shall be used only in the manner and for the purposes provided for by the Mesquite Zoning Ordinance, as amended.

SECTION 5. Should any word, sentence, clause, paragraph or provision of this ordinance be held to be invalid or unconstitutional, the remaining provisions of this ordinance shall remain in full force and effect.

SECTION 6. Any person (as defined in Chapter 1, Section 1-2 of the Code of the City of Mesquite, Texas, as amended) violating any of the provisions or terms of this ordinance shall be deemed to be guilty of a Class C Misdemeanor and upon conviction thereof, shall be subject to a fine not to exceed Two Thousand (\$2,000.00) Dollars for each offense, provided, however, if the maximum penalty provided for by this ordinance for an offense is greater than the maximum penalty provided for the same offense under the laws of the State of Texas, the maximum penalty for violation of this ordinance for such offense shall be the maximum penalty provided by the laws of the State of Texas. Each day or portion of a day any violation of this ordinance continues shall constitute a separate offense.

SECTION 7. This ordinance shall take effect and be in force from and after five days after publication.

DULY PASSED AND APPROVED by the City Council of the City of Mesquite, Texas, on the 16th day of August 2021.



---

Bruce Archer  
Mayor

ATTEST:



---

Sonja Land  
City Secretary

APPROVED AS TO LEGAL FORM:



---

David L. Paschall  
City Attorney

**EXHIBIT A – TRACT 1**

**LEGAL DESCRIPTION - 31.6679 ACRES**

**BEING** a tract of land situated in the John P. Anderson Survey, Abstract Number 1, City of Mesquite, Dallas County, Texas and being all that tract of land conveyed to N.E. Tittle, according to the document filed of record in Document Number 201500221896, Deed Record Dallas County, Texas (D.R.D.C.T.) said tract of land being more particularly described as follows:

**BEGINNING** at a 1/2" iron rod with plastic cap stamped "CLC SURVEYING" found in the southeasterly line of Mesquite Valley Road for the north corner of said Tittle tract, same being common with the west corner of that tract of land conveyed to The City of Mesquite, Texas according to the document filed of record in Document Number 201500001738 (D.R.D.C.T.) and being the common north corner of the tract described herein;

**THENCE** leaving said southeasterly line and with the common line of said Tittle and City of Mesquite tracts the following four (4) courses and distances;

South 14°26'52" East, a distance of 283.43 feet to a 1/2" iron rod with plastic cap stamped "CLC SURVEYING" found for a corner of this tract;

South 61°18'51" East, a distance of 406.77 feet to a 1/2" iron rod with plastic cap stamped "CLC SURVEYING" found for a corner of this tract;

South 26°50'33" East, a distance of 577.20 feet to a 1/2" iron rod with plastic cap stamped "CLC SURVEYING" found for a corner of this tract;

South 47°15'36" East, a distance of 215.34 feet to a 1/2" iron rod found for the east corner of said Tittle tract and this tract, same being common with the north corner of that tract of land conveyed to the City of Mesquite, Texas according to the document filed of record in Document Number 201500001691 (D.R.D.C.T.);

**THENCE** South 47°11'59" West, leaving said common corner and with the common line of said Tittle and City tract, a distance of 873.15 feet to a 1/2" iron rod with plastic cap stamped "CLC SURVEYING" found in the northeasterly line of that tract of land conveyed to the Mesquite I.S.D. according to the document filed of record in Volume 94101, Page 180 (D.R.D.C.T.) for the south corner of said Tittle tract and this tract;

**THENCE** North 45°53'16" West, with a portion of the northeast line of said I.S.D. tract, the northeast line of Cantura Cove Addition, an addition to the City of Mesquite, Dallas County, Texas according to the plat filed of record in Volume 2001100, Page 2739, Plat Records Dallas County, Texas, and the northeast line of that tract of land conveyed to Mesquite I.S.D. according to the document filed of record in Volume 93235, Page 2920 (D.R.D.C.T.) a distance of 1457.28 feet to a P/K Nail set in concrete for a common corner of said I.S.D. tract, Tittle tract and this tract;

**EXHIBIT A – TRACT 1**

**THENCE** North 51°45'09" West, continuing with the common line of said I.S.D. tract recorded in Volume 93235, Tittle tract and this tract, a distance of 123.08 feet to a 1/2" iron rod with plastic cap stamped "CLC SURVEYING" found in the above-mentioned southeasterly line of Mesquite Valley Road for the common corner of said tracts;

**THENCE** with said southeasterly line the following six (6) courses and distances:

North 83°06'41" East, a distance of 16.20 feet to a P/K Nail found in asphalt for a corner of this tract;

South 45°37'55" East, a distance of 14.44 feet to a 5/8" iron rod with plastic cap stamped "KHA" set for a corner of this tract;

North 82°07'30" East, a distance of 47.54 feet to a 5/8" iron rod with plastic cap stamped "KHA" set for a corner of this tract, at the beginning of a tangent curve to the left having a central angle of 38°26'43", a radius of 756.77 feet, a chord bearing and distance of North 62°54'09" East, 498.32 feet;

With said curve to the left, an arc distance of 507.79 feet to a 1/2" iron rod with plastic cap stamped "CLC SURVEYING" found for a corner of this tract;

North 44°06'02" East, a distance of 393.49 feet to a 1/2" iron rod with plastic cap stamped "CLC SURVEYING" found for a corner of this tract, at the beginning of a non-tangent curve to the right having a central angle of 12°05'41", a radius of 915.37 feet, a chord bearing and distance of North 49°20'40" East, 192.87 feet;

With said curve to the right, an arc distance of 193.23 feet to the **POINT OF BEGINNING** and containing 31.6679 acres or 1,379,455 square feet of land, more or less.

**EXHIBIT A – TRACT 2**

**LEGAL DESCRIPTION – 19.984 ACRES**

**BEING** all that certain, lot, tract, or parcel located in the JOHN ANDERSEN SURVEY, Abstract No. 1, City of Mesquite, Dallas County, Texas, and being the same called 20 acre tract of land described in deed to Esta Ruth Copeland, recorded in Volume 97124, Page 2892, Deed Records, Dallas County, Texas, and being more particularly described as follows:

**COMMENCING** at a point in the Southeasterly line of Mesquite Valley Road, a variable width right-of-way, as established in deed to the City of Mesquite, recorded in Volume 2743, Page 383, Deed Records, Dallas County, Texas, said point being at the West corner of a tract of land described in deed to N. E. Tittle, recorded in Volume 99206, Page 2520, Deed Records, Dallas County, Texas;

**THENCE** South 45°50'24" East, passing at a distance of 1434.46 feet a 5/8-inch iron rod found for reference at the East corner of a CANTURA COVE ADDITION PHASE 3, an Addition to the City of Mesquite, Dallas County, Texas, according to the plat thereof recorded in Volume 2001100, Page 2739, Map Records, Dallas County, Texas, and being the North corner of a tract of land described in deed to D. R. Horton, Ltd., recorded in Volume 99039, Page 2574, Deed Records, Dallas County, Texas, continuing a total distance of 1555.25 feet to a 1/2-inch iron rod with a yellow plastic cap stamped "RPLS 5310" set at the South corner of said Tittle tract, and being the PLACE OF BEGINNING of the tract described herein;

**THENCE** North 47°10'38" East, passing at a distance of 455.32 feet the East corner of said Tittle tract, continuing a total distance of 873.24 feet to a 1/2-inch iron rod with a yellow plastic cap stamped "RPLS 5310" set for corner in the Southwest line of a called 36 acre tract of land described in deed to Elouise Copeland, recorded in Volume 807, Page 389, Deed Records, Dallas County, Texas, at the East corner of a tract of land described in deed to W. K. Tittle, recorded in Volume 77168, Page 2172, Deed Records, Dallas County, Texas;

**THENCE** South 43°59'18" East, passing at a distance of 7.18 feet the Southerly corner of said 36 acre tract, same being the most Westerly corner of a tract of land described in deed to Ken Griffis and Ginger Griffis, recorded in Instrument No. 201300232101, Official Public Records, Dallas County, Texas, continuing a total distance of 250.17 feet to a 1/2-inch iron rod with a yellow plastic cap stamped "RPLS 5310" set for corner;

**THENCE** South 63°34'52" East, a distance of 32.96 feet to a 1/2-inch iron rod with a yellow plastic cap stamped "RPLS 5310" set for corner;

**THENCE** South 59°58'10" East, a distance of 50.10 feet a 1/2-inch iron rod with a yellow plastic cap stamped "RPLS 5310" set for corner at the most Southwesterly corner of said Griffis tract, same being the most Westerly Northwest corner of CREEK CROSSING ESTATES NO. 4, PHASE A, an Addition to the City of Mesquite, Dallas County, Texas, according to the plat thereof recorded in Volume 94230, Page 1111, Map Records, Dallas County, Texas:

**EXHIBIT A – TRACT 2**

**THENCE** Southeasterly, along the meanders of a creek and the Southwesterly line of said CREEK CROSSING ESTATES NO. 4, PHASE A, the following five (5) courses and distances:

South 11°35'52" East, a distance of 194.62 feet to a 1/2-inch iron rod with a yellow plastic cap stamped "RPLS 5310" set for corner;

South 82°43'25" East, a distance of 82.04 feet to a 1/2-inch iron rod with a yellow plastic cap stamped "RPLS 5310" set for corner;

South 78°54'50" East, a distance of 187.87 feet to a 1/2-inch iron rod with a yellow plastic cap stamped "RPLS 5310" set for corner;

South 64°49'58" East, passing at a distance of 160.00 feet a 1/2-inch iron rod with a yellow- plastic cap stamped "RPLS 5310" set for reference, continuing a total distance of 171.49 feet to a point for corner;

South 36°07'41" East, a distance of 92.10 feet to point at the most Northerly corner of CREEK CROSSING ESTATES NO. 7, PHASE II, an Addition to the City of Mesquite, Dallas County, Texas, according to the plat thereof recorded in Volume 96006, Page 4962, Map Records, Dallas County, Texas;

**THENCE** South 44°44'49" West, leaving said Creek, and along the Northwest line of said CREEK CROSSING ESTATES NO. 7, PHASE II, passing at a distance of 40.00 feet a 1/2-inch iron rod with a yellow plastic cap stamped "RPLS 5310" set for reference, continuing a total distance of 968.80 feet to a wood post found at the South corner of said called 20 acre tract, same being the East corner of Lot 1, Block A, JUDGE FRANK BERRY MIDDLE SCHOOL ADDITION, an Addition to the City of Mesquite, Dallas County, Texas, according to the plat thereof recorded in Volume 200025, Page 56, Map Records, Dallas County, Texas;

**THENCE** North 45°50'24" West, passing at a distance of 847.30 feet the Easterly Northeast corner of said JUDGE FRANK BERRY MIDOLE SCHOOL ADDITION, same being the South corner of said D. R. HORTON, Ltd. tract, continuing a total distance of 1002.93 feet to the **PLACE OF BEGINNING** and containing 870,488 square feet or 19.984 acres of land.

**EXHIBIT B**  
**PLANNED DEVELOPMENT STANDARDS**  
PAGE 1 of 3

The property shall be developed as single-family detached lots in accordance with the land uses and development standards for the (R-3) Single-Family District base zoning district with the following exceptions, special conditions, restrictions and regulations:

**General:**

1. Development shall be in general conformance with the following exhibits:
  - a. Concept Plan as shown on Exhibit C;
  - b. Typical Street & Utilities Section shown on Exhibit D.
2. A homeowner's association (HOA) shall be established prior to recording the final plat for the development.
3. The HOA will be responsible for the improvement and maintenance of all common areas and/or common facilities dedicated to the HOA.
4. No detailed tree survey shall be required. A tree exhibit showing existing tree canopies and the areas that are proposed to be removed and the areas proposed to remain shall be provided at the site plan stage. All tree preservation or remediation shall be addressed by the planting of street trees, buffer trees within the Mesquite Valley Road buffer area, entry trees, parkway trees, homebuilding planted trees on lots, etc.
5. Section D107 of the 2018 International Fire Code must be met. Deviations to the Concept Plan to comply with International Fire Code are permitted provided all other development standards are met.

**Streets and Utility Improvements:**

1. Streets shall be designed with a 50-foot wide street right-of-way, a 31-foot "back-to-back" pavement cross section and a 5-foot utility easement on either side of the street right-of-way for franchise utilities in accordance with Exhibit D.
2. Alleys are not required.
3. Water and Sanitary Sewer mains shall be located in the parkway between the back of curb and right-of-way line. Storm sewer mains shall be located in the center of the pavement.

**Lots and Homes:**

The development shall include 2 separate lot Types as shown on the Concept Plan:

1. Minimum lot area:
  - a. Type 1 Lots – 4,400 square feet;
  - b. Type 2 Lots – 5,500 square feet;
2. Minimum floor area of homes:
  - a. Type 1 Lots – 50% of the Type 1 Lots shall have a minimum floor area of 1,500 square feet and 50% of the Type 1 Lots shall have a minimum floor area of 1,600 square foot;
  - b. Type 2 Lots – 1,800 square foot minimum for all Type 2 Lots;
3. Maximum building coverage, excluding lead walks, driveways, patios, and other flatwork;
  - a. Type 1 and Type 2 Lots: 60%
4. Minimum lot width (measured along the front building line):
  - a. Type 1 Lots – 40 feet;

**EXHIBIT B**  
**PLANNED DEVELOPMENT STANDARDS**  
PAGE 2 of 3

- b. Type 2 Lots – 50 feet;
- c. For all lots on cul-de-sacs and around “eyebrows” the minimum frontage of the lot shall be 30 feet measured along the right-of-way;
- 5. Minimum lot depth (Type 1 and Type 2 Lots):
  - a. 110 feet;
  - b. For all lots on cul-de-sacs and around “eyebrows” the minimum lot depth shall be 90 feet;
- 6. Minimum Setbacks (Type 1 and Type 2 Lots):
  - a. Minimum front yard setback shall be 20 feet;
  - b. Minimum interior side yard setback shall be 5 feet;
  - c. Minimum street side yard setback shall be 10 feet on standard lots and 20 feet on key lots;
  - d. Minimum rear yard setback shall be 10 feet;
  - e. On corner lots, the “corner clips/right-of-way radii” shall not be considered when measuring setbacks. In no case shall buildings, structures, or fencing impact site visibility.
- 7. Carports are prohibited.
- 8. Front-entry garages are permitted.
- 9. Driveways on corner lots shall be located a minimum of 30 feet from the back of curb on the adjacent side street to the edge of the driveway at the right-of-way.
- 10. At the time of home construction, homebuilders shall plant a minimum of one 3” caliper tree in the front yard for every lot.

**Amenities:**

- 1. Open Space/Parkland:

Open Space or Parkland shall be provided in general conformance with Exhibit C and shall include the following:

  - a. A minimum 40-foot wide landscape buffer will be provided along Mesquite Valley Road;
  - b. Open Space/Parkland will be provided along the easterly boundary adjacent to the existing North Mesquite Creek. Passive park improvements shall be provided in the Open Space/Parkland;
  - c. Open Space shall be provided for the sidewalk/trail linkage in the interior block of the development;
  - d. No Parkland dedication or fees-in-lieu-of land shall be required for the project in consideration fo the Open Space/Parkland provided.
- 2. Landscaping:

The landscape buffer along Mesquite Valley Road shall include the following:

  - a. A minimum of two shade trees for each 100 feet or fraction thereof, five ornamental trees for each 100 linear feet or fraction thereof, and 65 shrubs or ornamental grasses for each 100 linear feet or fraction thereof.

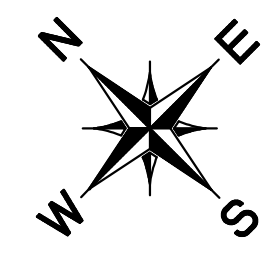

**EXHIBIT B**  
**PLANNED DEVELOPMENT STANDARDS**  
**PAGE 3 of 3**

3. Sidewalks/Trails:
  - a. The developer shall construct the following sidewalks/trails:
    - i. 6' sidewalk/trail generally meandering through the Open Space along Mesquite Valley Road;
    - ii. 6' sidewalk/trail generally meandering through the Open Space along the existing North Mesquite Creek on the east side of the development;
    - iii. 6' sidewalk/trail along the southeasterly boundary of the project;
    - iv. 5' sidewalk/trail through the Open Space in the interior block of the development;
    - v. 5' sidewalks within right-of-way adjacent to any Open Space that does not include a sidewalk/trail noted in the previous items above;
  - b. Homebuilders shall construct 5' sidewalks along the entire frontage of each individual lot within the right-of-way (including side of the lot for corner lots) at the time the home is constructed. Sidewalks shall be constructed in the public right-of-way and located at the back of the right-of-way line per Exhibit D.
  - c. Sidewalks/trails shall be constructed of concrete or other material approved by the City.
  - d. No additional sidewalks or trails, other than those identified on the Exhibit C Zoning Concept Plan will be required within the boundary of the development. The trails shown on Exhibit C provide connection to the trail network for Copeland Park.
4. Walls and Fencing:
  - a. A masonry fence or a wrought iron fence with living screen shall be provided along the rear lot line for the lots backing to Mesquite Valley Road.
  - b. Along the westerly boundary open space that is adjacent to the existing BJ Smith Elementary School property, there will be a 48" wrought iron fencing with landscaping.
  - c. A minimum of 6-feet in height, cedar wood fence shall be provided along the southwesterly property boundary adjacent to the Cantura Cover Subdivision within a 5' open space maintained by the HOA.
  - d. A minimum of 6-feet in height, cedar wood fence shall be provided along the southern property boundary adjacent to the Creek Crossing Estates Subdivision.
  - e. A 48" wrought iron fence or a 6' height cedar wood fence shall be provided along the eastern boundary abutting the floodplain and Copeland Park.
  - f. No additional perimeter walls or fencing will be required.



EXHIBIT C - CONCEPT PLAN



SITE DATA TABLE	
EXISTING ZONING	AG
PROPOSED ZONING	PD (R-3 BASE ZONING)
FUTURE LAND USE	LOW DENSITY RESIDENTIAL
<b>GROSS AREA</b> 51.64 ac	
<b>PRIVATE OPEN SPACE AREA</b> 3.34 ac	
<b>PUBLIC OPEN SPACE</b> 11.32 ac	
<b>% OPEN SPACE</b> 28.39%	
LOT SUMMARY	
TYPE 1 (40' LOTS)	175
TYPE 2 (50' LOTS)	60
<b>TOTAL LOT COUNT</b>	<b>235</b>

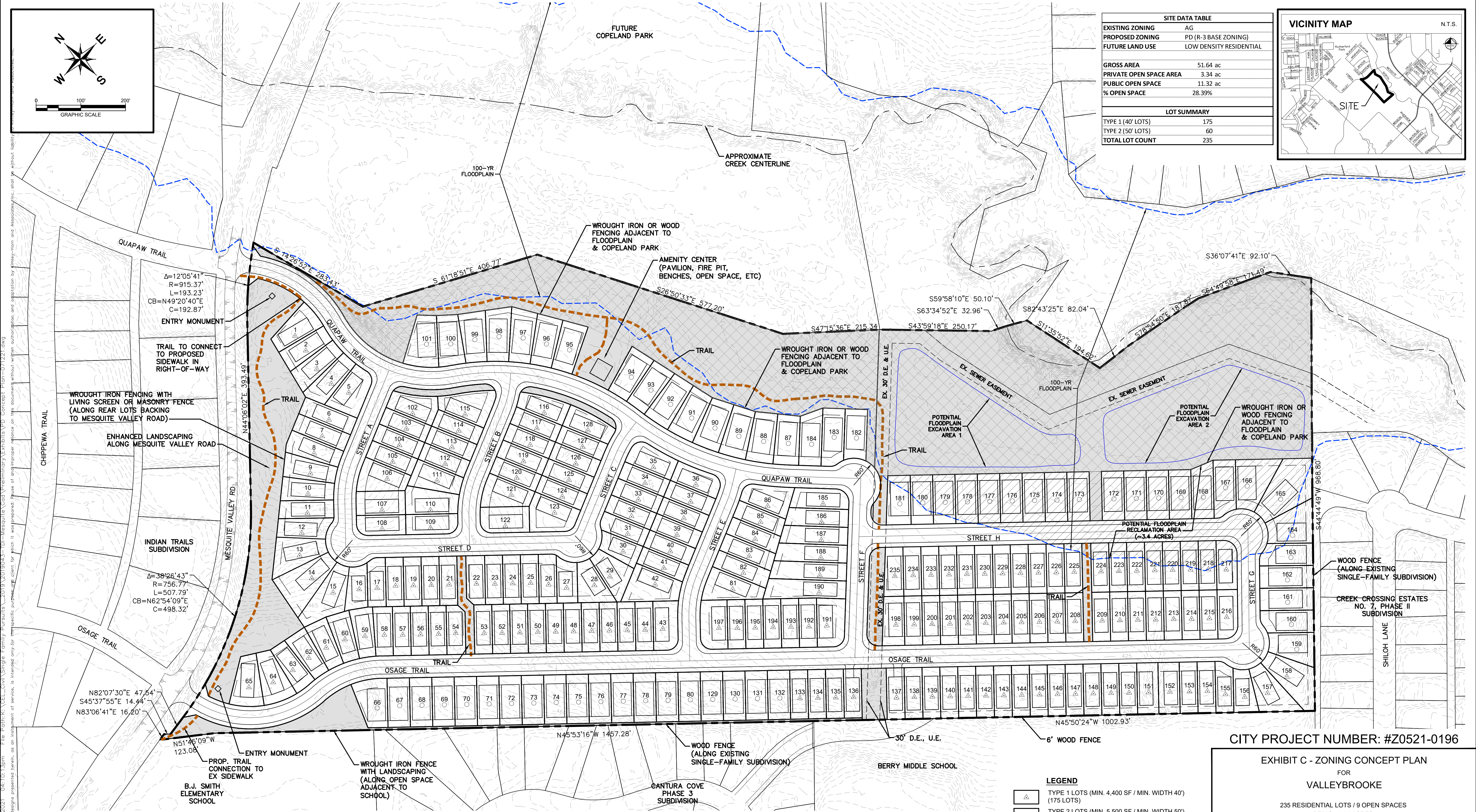
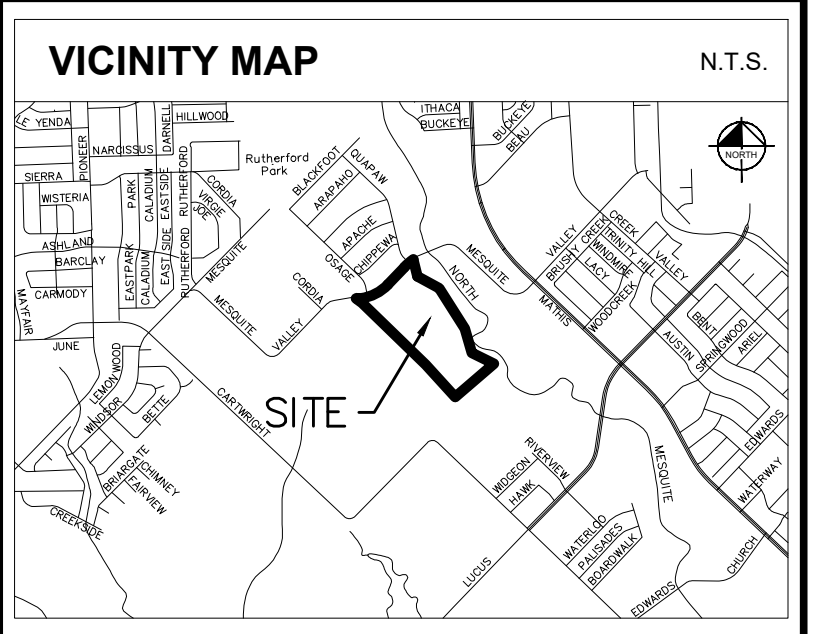

Plotted By: Lusk, L01 Date: July 12, 2021 04:10:13pm File Path: K:\CELL\Draw\Single Family Pursuits\_2019\20190403-DI-Mesquite\Code\Preliminary\Exhibits\VPD Concept\_Plan-071221.dwg  
 This document, together with the concepts and designs presented herein, is intended only for the specific purpose and client for which it was prepared. Please do not disseminate or use this document without written authorization, and adaptation by Kinley-Horn and Associates, Inc. shall be without liability.

$\Delta = 12^{\circ}05'41''$   
 $R = 915.37'$   
 $L = 193.23'$   
 $CB = N49^{\circ}20'40''E$   
 $C = 192.87'$

$\Delta = 38^{\circ}26'43''$   
 $R = 756.77'$   
 $L = 507.79'$   
 $CB = N62^{\circ}54'09''E$   
 $C = 498.32'$

$N82^{\circ}07'30''E$  47.54'  
 $S45^{\circ}37'55''E$  14.44'  
 $N83^{\circ}06'41''E$  16.20'  
 $N51^{\circ}46'09''W$  123.08'

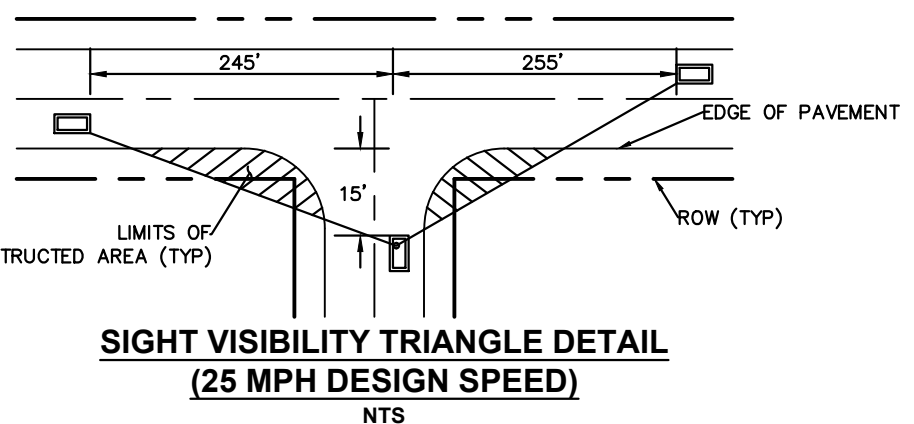

- NOTES:**
- THE THOROUGHFARE ALIGNMENT(S) SHOWN ON THIS EXHIBIT ARE FOR ILLUSTRATION PURPOSES AND DOES NOT SET THE ALIGNMENT. THE ALIGNMENT IS DETERMINED AT THE TIME OF PLAT.
  - ALL CURRENT DEVELOPMENT REQUIREMENTS OF THE CITY AS AMENDED SHALL BE MET UNLESS APPROVED OTHERWISE WITHIN THESE PLANNED DEVELOPMENT ZONING DISTRICT DEVELOPMENT REGULATIONS.
  - THIS ZONING CONCEPT PLAN IS FOR ILLUSTRATIVE PURPOSES ONLY AND SUBJECT TO CHANGE. THIS ZONING CONCEPT PLAN, ALONG WITH DEVELOPMENT REGULATIONS, IS INTENDED TO DESCRIBE THE INTENT OF THE PLANNED DEVELOPMENT. SIGNIFICANT DEVIATIONS FROM THIS ZONING CONCEPT PLAN, AS DETERMINED BY THE DIRECTOR OF PLANNING AND DEVELOPMENT SERVICES, WILL REQUIRE AN AMENDMENT TO THE ZONING CONCEPT PLAN AND, AS NECESSARY, THE DEVELOPMENT REGULATIONS.
  - ALL INTERSECTIONS SHALL ADHERE TO VISIBILITY REQUIREMENTS STATED IN SECTION 2.4 OF THE 2019 CITY OF MESQUITE ENGINEERING DESIGN MANUAL. PLEASE REFER TO THE DETAIL ON THIS EXHIBIT FOR SIGHT VISIBILITY REQUIREMENTS.

**LEGEND**

	TYPE 1 LOTS (MIN. 4,400 SF / MIN. WIDTH 40') (175 LOTS)
	TYPE 2 LOTS (MIN. 5,500 SF / MIN. WIDTH 50') (60 LOTS)
	PRIVATE OPEN SPACE (~3.3 ACRES)
	PUBLIC OPEN SPACE (~11.4 ACRES)
	FLOODPLAIN RECLAMATION AREA (~3.4 ACRES)
	PROPOSED TRAIL (BY DEVELOPER)

CITY PROJECT NUMBER: #Z0521-0196

**EXHIBIT C - ZONING CONCEPT PLAN**  
 FOR  
**VALLEYBROOKE**  
 235 RESIDENTIAL LOTS / 9 OPEN SPACES  
 BEING 51.64 ACRES  
 OUT OF THE  
 JOHN P. ANDERSEN SURVEY, ABSTRACT NO. 1  
 IN THE  
**CITY OF MESQUITE, DALLAS COUNTY, TEXAS**

<b>OWNER:</b> Sky Twilighten 3719 FM 2727 Kaufman, TX 75142 Tel: (972) 877-1235 Contact: Sky Twilighten	<b>APPLICANT/DEVELOPER:</b> Taylor Duncan Interests, LLC 15441 Knoll Trail, Suite 150 Dallas, TX 75249 Tel: (972) 404-8500 Contact: Stephen Davis	<b>ENGINEER/SURVEYOR:</b> <b>Kimley-Horn</b> 400 N. Oklahoma Dr., Suite 105 Celina, TX 75009 Tel: (469) 501-2200 Contact: Craig Malan, P.E.
--	--	--

DESIGNED	DRAWN	CHECKED	SCALE	DATE	KH PROJECT NO.
XXX		XXX	AS SHOWN	MAY 2021	PROJECT NUMBER



EXHIBIT D

TYPICAL STREET SECTION AND UTILITY LOCATION EXHIBIT  
50 FT R.O.W. WITH 31' BACK-TO-BACK PAVEMENT  
WITH 5' UTILITY EASEMENT

N.T.S.

